

(No Model.)

T. A. EDISON.  
ELECTRICAL CONDUCTOR.

No. 304,087.

Patented Aug. 26, 1884.

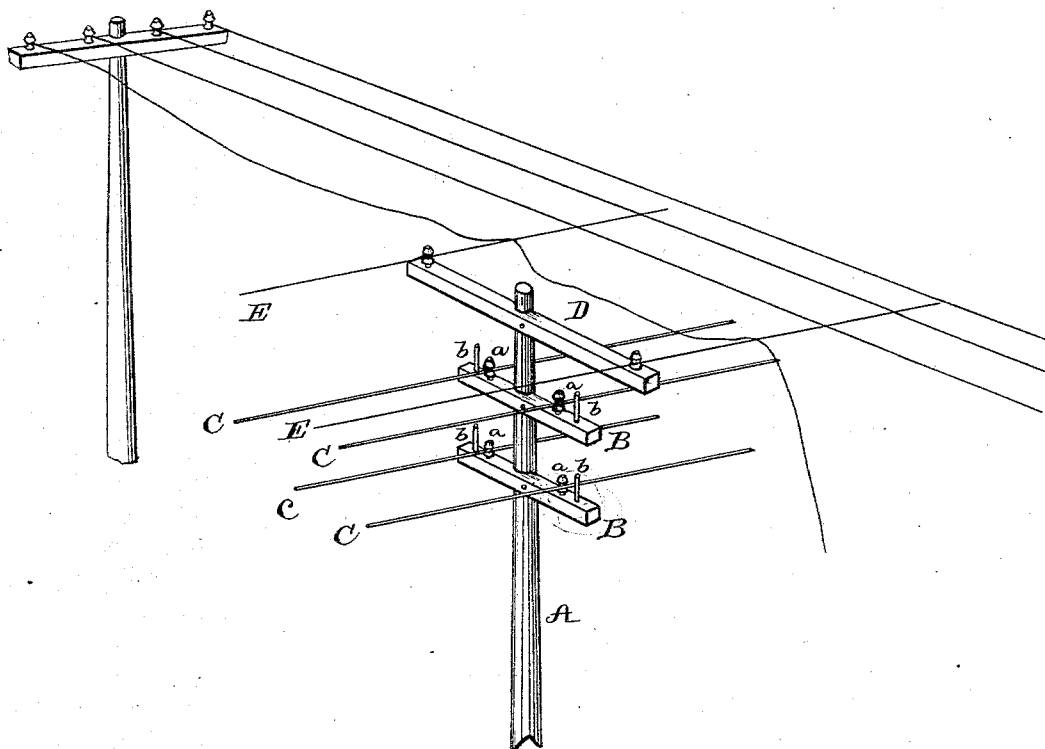

WITNESSES:

*E. P. Rowland*  
*A. W. Lacey*

INVENTOR:

*Thomas A. Edison*  
*By Rich<sup>d</sup>. A. Dyer*  
*Att<sup>y</sup>.*

# UNITED STATES PATENT OFFICE.

THOMAS A. EDISON, OF MENLO PARK, NEW JERSEY.

## ELECTRICAL CONDUCTOR.

SPECIFICATION forming part of Letters Patent No. 304,087, dated August 26, 1884.

Application filed January 24, 1884. (No model.)

*To all whom it may concern.*

Be it known that I, THOMAS A. EDISON, of Menlo Park, in the county of Middlesex and State of New Jersey, have invented a new and useful Improvement in Electrical Conductors, (Case No. 613,) of which the following is a specification.

When the conducting-wires of an electric-lighting system are placed overhead upon poles, it is necessary to provide some means for completely isolating such wires, thereby preventing telegraph, telephone, or other wires from coming in contact with them, whereby the powerful currents of the lighting-wire would be transmitted to the instruments in connection with the other wires, and also preventing the lighting-wires themselves from falling from the poles, should they become detached from the insulators, and coming in contact with other wires, or with any object contact with which would be undesirable. The first of these objects I accomplish by the use of guard-wires placed upon the poles above the lighting-wires, and which prevent the other wires from falling across or into contact with the lighting-wires. I extend the cross-pieces to which the guard-wires are attached out farther on either side than those which carry the lighting-wires, and so bring the guard-wires well outside of the vertical plane of the lighting-wires, so that it is impossible for any crossing wires coming from above to reach the latter. To prevent the lighting-wires themselves from leaving the poles, and thus from falling upon other wires, or upon any object below them, I place supports upon the cross-pieces outside the insulators. These supports are preferably pins inserted in the wood of the cross-piece, and of such height that should the insulator be broken, or the wire in any way become detached from it, the pin

will keep said wire from reaching the end of the cross-piece. The guard-wires may be of small size, and may be used, if desired, as testing-wires for determining the electrical condition of the different parts of the system. Beyond the ends of the feeding-conductors, however, they are not so used.

My invention is illustrated in the accompanying drawing, which represents the upper portion of one of the poles in a line of an electric-lighting system.

A is the pole, and B B are cross-pieces which carry the electric-lighting conductors C C, which are attached to suitable insulators, *a a*. Above them is placed a larger cross-piece, D, which carries the guard-wires E E, these being placed outside the lighting-wires for the purpose mentioned. Pins or supports *b b* are placed outside the insulators on the cross-pieces B B, which prevent the wires from ever leaving the cross-pieces.

What I claim is—

1. The combination, with electrical conductors placed upon poles, of guard-wires placed above them, substantially as set forth.
2. The combination, with electrical conductors placed upon poles, of guard-wires placed above them and outside their vertical plane, substantially as set forth.
3. The combination, with electrical conductors placed upon cross-pieces upon poles, of a longer cross-piece above them carrying guard-wires placed outside their vertical plane, substantially as set forth.

This specification signed and witnessed this 12th day of January, 1884.

THOS. A. EDISON.

Witnesses:

H. W. SEELY,  
EDWARD H. PYATT.