

(No Model.)

T. A. EDISON.
ELECTRIC RAILWAY.

No. 448,778.

Patented Mar. 24, 1891.

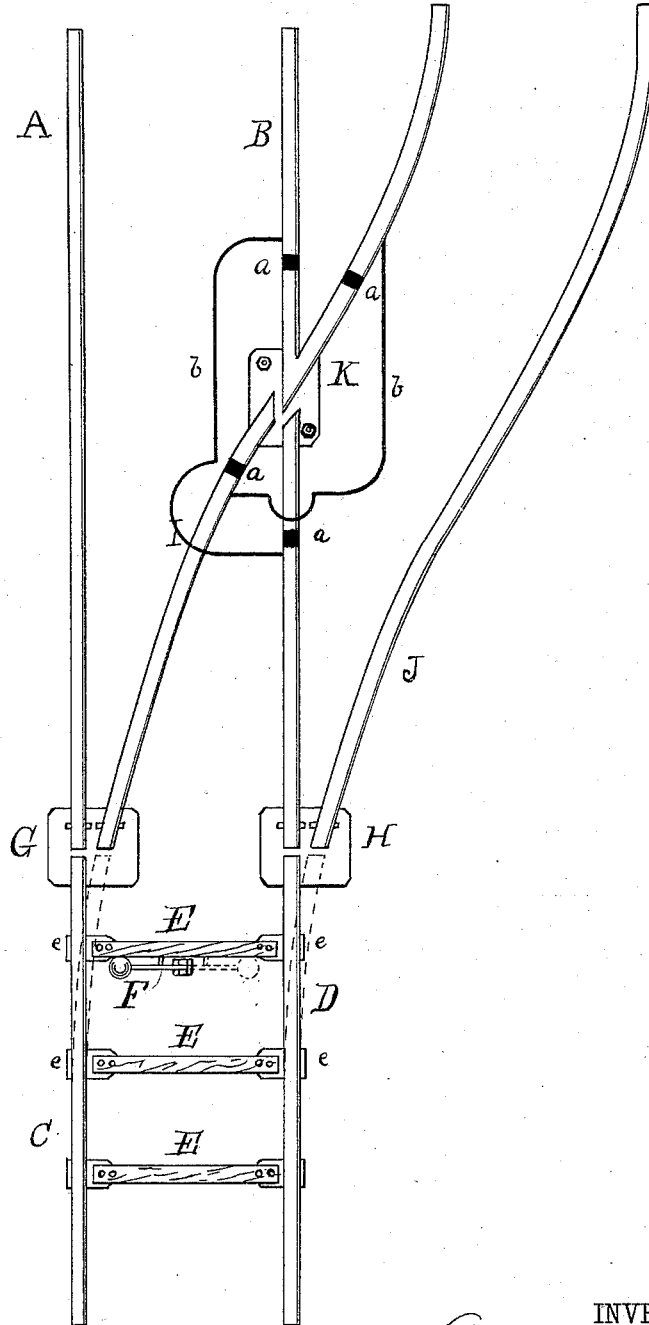

WITNESSES:

E. C. Rowland
W. Wheeler

INVENTOR:

Thomas A. Edison,
By Rich^d. N. Dyer,
Att^y.

UNITED STATES PATENT OFFICE.

THOMAS A. EDISON, OF MENLO PARK, NEW JERSEY, ASSIGNOR TO THE
EDISON ELECTRIC LIGHT COMPANY, OF NEW YORK, N. Y.

ELECTRIC RAILWAY.

SPECIFICATION forming part of Letters Patent No. 448,778, dated March 24, 1891.

Application filed August 7, 1882. Serial No. 68,650. (No model.)

To all whom it may concern:

Be it known that I, THOMAS A. EDISON, of Menlo Park, in the county of Middlesex and State of New Jersey, have invented a new and useful Improvement in Electric Railways; and I do hereby declare that the following is a full and exact description of the same, reference being had to the accompanying drawing and to the letters of reference marked thereon.

My invention relates to electric railways in which the current is conveyed from a source of energy by stationary conductors to an electric motor mounted upon and propelling a car or train of cars, and especially to that class of electric railways in which the rails of the track form the conductors for the current, one line of rails forming one conductor or one side of the circuit and the other line of rails an opposite conductor or side of the circuit, the rails being sufficiently insulated from each other; and my invention consists in a novel arrangement and construction of switches or sidings for such railways as hereinafter set forth, and specified in the claims.

The accompanying drawing represents my invention partly in diagram.

A and B are the stationary rails of the main track, each line of rails forming one conductor of the supplying-circuit.

C and D are switch-rails of the main track.

The switch-rails C D are connected together mechanically, but insulated electrically from each other by wooden bars E E, each of such bars being provided at each end with a metal shoe *e*, in which the rail is held. The switch-lever F for moving the switch is attached to the first of said bars E.

The ends of the switch-rails C D and of the stationary rails A B of the main line rest on metal plates G H, on which rest also the ends of the rails I and J of the side track. The plates G H thus complete electrically the line of each of the main-track conductors, which would otherwise be broken at the point of connection with the conducting-rails of the branch or side track, and such plates also complete the circuit-connections from the conductors of the main track to those of the branch or side track, the two branch-line or side-track conductors being thus connected to the main-

line conductors in permanent multiple-arc connection.

In the position of the parts shown in the drawing the car-wheels or other current-collecting devices which travel upon the conducting-rails and take current therefrom will pass directly along the main line in either direction, but if the movable rails C D are shifted into the position shown in dotted lines the ends of said rails, moving across the plates G H, are brought into juxtaposition with the ends of the branch or side track rails I J, so that the car-wheels or current-collecting devices may pass from the main track to the branch track, the conductors of the branch track being supplied with current through the switch-plates G H without regard to the position of the movable ends of the conductors C D upon said plates.

At the frog K short sections of rails B and I are cut out electrically by the insulating spaces or sections *a a*. The necessary connections are made around the insulated frog by means of wires *b b* or in any other suitable manner. By this arrangement a short circuit of the main-track circuit by the branch rail I is prevented, and the insulating-sections also prevent a short circuit of the main track when the car-wheel or other current-collector passes between I and B, which would occur if the rails were insulated immediately at the frog.

What I claim is—

1. In an electric railway, two main-line conductors, in combination with a source of electric energy therefor, and two branch-line conductors connected to the main-line conductors in permanent multiple-arc connection, substantially as set forth.

2. In an electric railway, two rails of a main track, in combination with a source of electric energy connected therewith, and two rails of a branch or side track electrically connected with the main rails in permanent multiple-arc connection, substantially as set forth.

3. In an electric railway, the combination of a main-line conductor, a branch-line or side-track conductor extending therefrom, and a conducting switch-plate joining the extremities of said conductors, substantially as set forth.

4. In an electric railway, the combination of a broken main-line conductor, a conducting switch-plate connecting the meeting extremities of the separated portions, and a
5 branch-line or side-track conductor connected with and extending from the same switch-plate, substantially as set forth.

5. In an electric railway, the combination of a broken main-line conductor, a conducting
10 switch-plate, the meeting ends of the separated portions of said conductor extending upon the surface of said switch-plate, and a branch-line or side-track conductor also extending from the surface of said switch-plate,
15 substantially as set forth.

6. In an electric railway, the combination of a broken main-line conductor, a conducting switch-plate, the meeting ends of the separated portions of said conductor extending
20 upon the surface of said switch-plate, and a

branch-line or side-track conductor also extending from the surface of said switch-plate, the end of one of said conductors being movable laterally upon the switch-plate, substantially as set forth. 25

7. In an electric railway, the combination of a main-line conductor, a conducting switch-plate upon the surface of which the said conductor and a main-line conductor extend and a
30 branch-line or side-track conductor extending from the other end of said switch-plate, the end of the first-mentioned main-line conductor being movable laterally upon the switch-plate, substantially as set forth.

This specification signed and witnessed this
5th day of August, 1882. 35

T. A. EDISON.

Witnesses:

H. W. SEELY,
EDWARD H. PYATT.