

No. 850,912.

PATENTED APR. 23, 1907.

T. A. EDISON.

PROCESS OF MAKING ARTICLES BY ELECTROPLATING.

APPLICATION FILED OCT. 5, 1903.

2 SHEETS—SHEET 1.

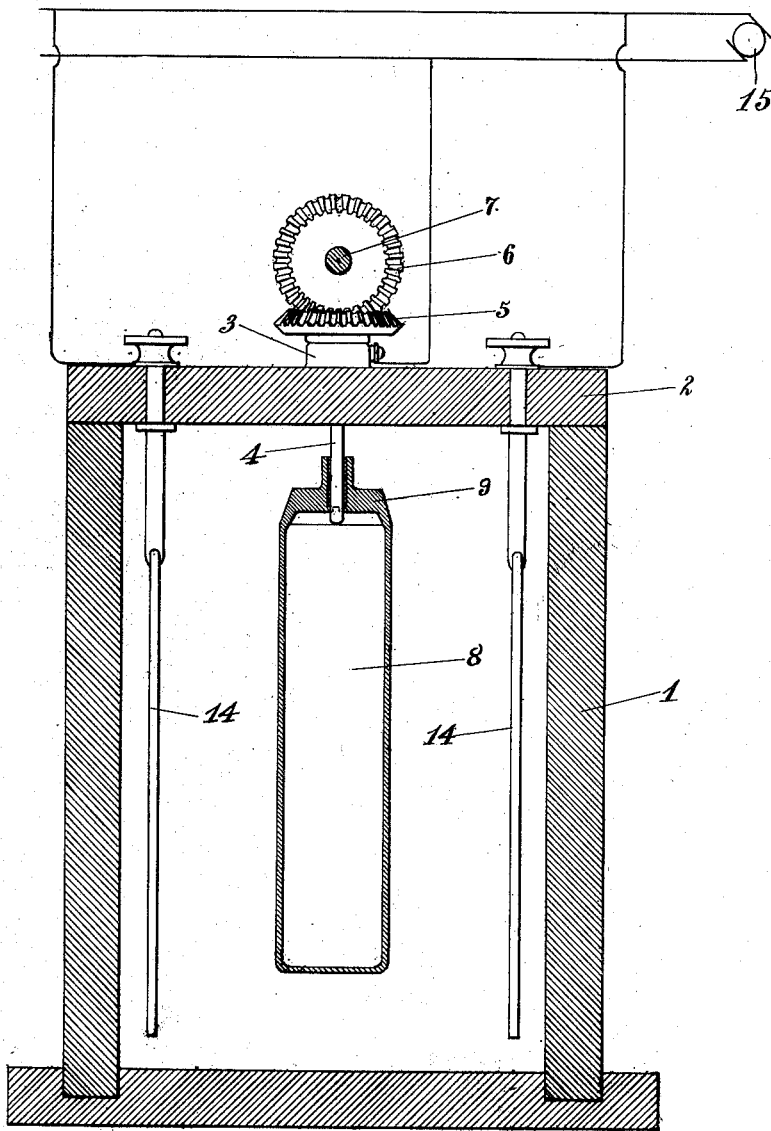

Fig. 1

Witnesses:

Ludwig Witt  
Wm A. Dalau

Inventor

Thomas A. Edison  
by Samuel L. Green  
Attorneys.

No. 850,912.

PATENTED APR. 23, 1907.

T. A. EDISON.  
PROCESS OF MAKING ARTICLES BY ELECTROPLATING.

APPLICATION FILED OCT. 6, 1903.

2 SHEETS—SHEET 2.

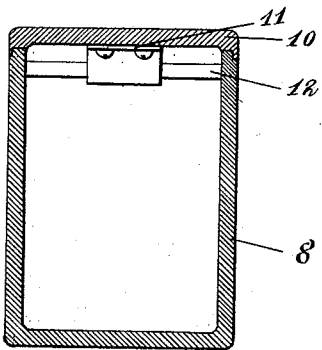

Fig. 3

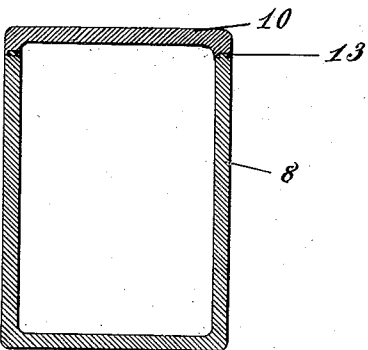

Fig. 4

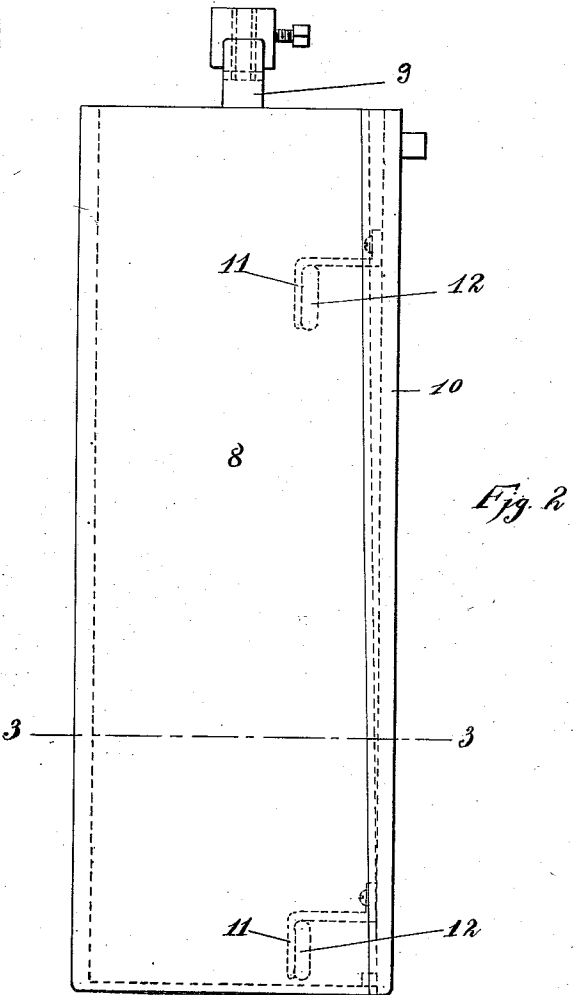

Fig. 2

Witnesses:

*Andrew G. Cott*

*William A. Baker*

Inventor

*Thomas A. Edison*

*By* *George F. Owen*  
Attorneys.

# UNITED STATES PATENT OFFICE.

THOMAS A. EDISON, OF LLEWELLYN PARK, ORANGE, NEW JERSEY.

## PROCESS OF MAKING ARTICLES BY ELECTROPLATING.

No. 850,912.

Specification of Letters Patent.

Patented April 23, 1907.

Application filed October 5, 1903. Serial No. 175,818.

*To all whom it may concern:*

Be it known that I, THOMAS A. EDISON, of Llewellyn Park, Orange, in the county of Essex, State of New Jersey, have invented certain Improvements in the Processes of Making Articles by Electroplating, of which the following is a description.

My invention relates to an improved process for making articles by electroplating, and particularly for making cans or receptacles for use with storage batteries of my improved type and as I describe in an application for Letters Patent, filed on even date herewith, Serial No. 175,819. The process has been gotten up especially with the object in mind of making such cans or receptacles of iron; but it may be carried out for the manufacture of other articles and from other metals or combinations thereof. The particular value of a can or receptacle for storage batteries made by a plating process as I shall describe resides in the fact that such an article is entirely seamless, so that the necessity is done away with of employing solder, which may be affected by the alkaline electrolyte used with such batteries. The problem of making a storage battery can or receptacle or other essentially hollow article by a plating process of iron presented very great practical difficulties, since such metal during a plating operation tends to contract, and unless special provision is made to overcome the same the contraction will result in the metal cracking or scaling from any molds or forms on which it may be plated. Furthermore, in the plating of iron the formation of gas-bubbles would result in the deposited coating being pitted or actually perforated, which would of course destroy the utility of the completed article. Furthermore, an electrodeposited coating of iron is extremely weak and brittle in nature, and articles made therefrom without subsequent treatment would not be available for commercial use.

The process which I have invented and which will be presently described has been evolved after a long series of experiments and results in the production of a plated article, such as a battery can or receptacle, which may be made of iron, which will be perfectly smooth and coherent throughout, being entirely free of pits or holes, and which when finished is very strong and tough.

In order that the invention may be better understood, attention is directed to the ac-

companying drawings, forming a part of this specification, and in which—

Figure 1 is a cross-sectional view taken through one of the plating-tanks which is used in carrying my process into effect, the assumption being made that the articles which are to be produced are one-piece iron battery cans or receptacles; Fig. 2, a separate side elevation of the mold or former used in the manufacture of such cans or receptacles; Fig. 3, a cross-sectional view on the lines 3 3 of Fig. 2 looking downward; and Fig. 4, a view corresponding to Fig. 3, showing a modification.

In all of the above views corresponding parts are represented by the same numerals of reference.

In the carrying of my process into effect and in the preferred embodiment thereof I make use of three plating-tanks, in which distinct plating operations take place. I prefer to use three separate tanks in order that the operations may be continuous, so that while one plating is going on in one tank a succeeding plating may be taking place in another tank, and so on. It will, however, be understood that the same tank may be used for the several platings, although in that case it will obviously have to be cleaned out and a fresh solution used for the subsequent plating-operations. The several tanks used may be all of the same construction, so that a description of one will suffice for all.

The tank 1 is in the form of a long open trough having one or more wooden cross-pieces corresponding to the several molds or formers which may be used therein. Each cross-piece 2 is formed with a bearing 3, in which is mounted a vertical shaft 4, having a bevel-gear 5 at its upper end. Meshing with each of the gears 5 is a bevel-gear 6 on a longitudinal shaft 7. In this way it will be obvious that a plurality of the shafts 4 may be driven from the same main shaft. Each of the molds 8 is made of the proper form or shape, being composed, preferably, of brass or copper and being hollow, so as to be as light as possible. Each mold is provided with a bridge-piece 9 at its upper end, with which the lower threaded end of the shaft 4 engages, so that the mold will be rotated by said shaft. Each of the molds is provided with a removable section 10, which may be separated from the main portion of the mold to facilitate the removal of the completed article, as will be explained. The removable section

10 of each mold may be normally held in position in any suitable way—as, for example, by means of a hook 11, engaging over a bridge-piece 12, as shown in Figs. 2 and 3, or  
5 by a dovetailed joint 13 between the two sections, as shown in Fig. 4. The mold 8 constitutes the cathode of the plating-bath, suitable anodes 14 being arranged therein and being connected with a suitable source  
10 of supply 15—either a battery or plating-dynamo. The mold 8 is preferably slightly tapered toward its lower end to facilitate the removal of the completed article. This taper may be very slight indeed and need not be  
15 more than one-sixteenth of an inch.

Assuming three plating-baths to be employed and the preferred process to be carried out in connection with the manufacture of battery cans or receptacles of iron, I proceed substantially as follows: The mold is  
20 first dipped in melted paraffin-wax maintained at a temperature of about 100° centigrade, so as to coat the mold with a very thin layer thereof. This layer need not be more than .005 to .025 inch in thickness. After the wax layer has cooled and congealed I apply thereto a conducting material in finely-divided form, preferably graphite,  
25 so as to entirely coat the mold, the coating of wax being so thin that the graphite apparently makes contact through the same with the mold. I prefer to make use of a preliminary coating of wax, as explained, since this not only facilitates the application of the graphite, but also permits the article when  
30 finished to be readily removed. The coated mold is now placed in a copper bath with copper anodes and is copper-plated to a thickness of about .004 inch, more or less. The solution used may be the ordinary copper-sulfate, (CuSO<sub>4</sub>) solution. After the plating of copper has been applied the mold is removed and washed and introduced into a second tank having a nickel-plating solution therein. Any suitable solution may be employed, such as a nickel-ammonium-sulfate solution. In this bath the mold is plated with an extremely thin coating of nickel about .001 inch in thickness. The mold is  
40 then removed and washed and put into the third tank employing iron electrodes and having a solution consisting, preferably, of ferrous-ammonium sulfate, Fe(H<sub>4</sub>N)<sub>2</sub>(SO<sub>4</sub>)<sub>2</sub>. It is important that this iron solution should be absolutely neutral and free from ferric salts, since the presence of any traces of acidity or of ferric salts affects the character of the plating, making it very brittle and causing it to scale or flake off of the mold.  
55 It will be understood that a solution of ferrous sulfate may alone be used; but I prefer to use ammonium sulfate therewith, as in this way the conductivity of the bath will be increased, while the coherence and smoothness of the resulting coating of iron will be

very materially improved. The solution used may be from twelve per cent. to fifteen per cent. of the double salt. In order that the possibility of the bath becoming acid may be prevented, I preferably add small quantities of ammonia or other alkali thereto at suitable intervals. The plating of iron is effected, preferably, by a current of about one to 1.2 amperes per square decimeter of surface. The plating of iron is continued for from thirty to thirty-five hours at a temperature of not below 40° centigrade, thereby giving a coating about .020 inch in thickness. If the bath is materially cooler than this—say at the ordinary temperatures—I  
70 have found from my experiments that the deposit tends to crack after a few hours. It will of course be understood that when heavier or lighter layers of iron require to be deposited the time during which the coating takes place will be proportionately increased or diminished. In order to prevent the formation of pits or holes in the deposited iron coating, which would be likely to form by the accumulation of gas-bubbles thereon, and to secure a very smooth surface, I introduce a quantity of crushed charcoal into the solution, whereby the added material will rub over and scour the surface of the deposited metal to polish the same and wipe off any gas-bubbles which may tend to accumulate thereon. Furthermore, I find that a small percentage of carbon will in this way be incorporated with the deposited iron, which therefore in the subsequent annealing is converted practically into a superior product of soft steel containing according to my analysis almost .4 per cent of carbon. As a result the finished article is considerably tougher and more rigid than when made of pure iron. Such particles of charcoal may vary in dimension between one-sixteenth to one-eighth of an inch in size. Of course it may be possible that other materials may be used for this purpose; but I have found that charcoal is very desirable for this use. The amount of charcoal which is thus added to the solution may obviously vary within quite wide limits; but good results are secured when the bulk of charcoal introduced is about one-half the bulk of the solution, so that if the charcoal is allowed to float it will form a layer extending about half the thickness of the solution in the tank. During the iron plating the mold is revolved at a speed of about ninety turns per minute; but this speed is also variable and need not be strictly adhered to. After a plating of iron of the desired thickness has been formed on the mold the latter is removed from the tank and washed in water at a temperature of about 75° centigrade, thereby melting the wax originally deposited on the mold, after which by removing the removable section of the mold the resulting casing or can or other

article can be separated therefrom, as will be understood. Iron which has been thus plated on a mold is extremely brittle, and in order that it may be made tough and strong I prefer to anneal the same. For this purpose the articles after plating are introduced into a closed retort and heated to a red heat, being then allowed to slowly cool. Preferably this heating of the articles is effected in a non-oxidizing atmosphere, such as in an atmosphere of hydrogen gas, so as to remove any possibility of oxidizing, and after annealing the articles are allowed to cool in the same atmosphere.

In the case of storage-battery cans or receptacles it is necessary that the copper originally deposited on the graphite should be removed, since this metal is slightly soluble in an alkaline electrolyte in the presence of electrolysis. This removal of the original copper coating is preferably effected by filling the can or receptacle with a solution of a mixture of copper nitrate,  $\text{Cu}(\text{NO}_3)_2$ , and sodium nitrate,  $(\text{NaNO}_3)_2$ , or sodium nitrate alone be used in the solution. The can or receptacle is now used as an anode of a plating-bath, a copper cathode being introduced therein and a plating-current applied. When the solution contains copper nitrate, as is preferable, the copper will be plated off from the inside of the can or receptacle and be recovered on the cathode; but when sodium nitrate is alone used the copper thus removed forms insoluble copper hydrate, which can be recovered from the solution in any suitable way. I prefer to apply a preliminary coating of copper, since I find that the iron tends to crack after a few hours plating, owing to its tendency to constantly contract, and the copper appears to offer a base or foundation on which the iron is deposited and which resists the tendency to contraction. The deposit of nickel is applied to the copper in order that the final article may be provided with a nickel interior. This is of importance in connection with cans or receptacles for storage batteries in order that the iron may be protected from the effects of any erratic electrolytic action in the alkaline solution. Of course it will be possible and in some instances desirable to apply the nickel subsequently to the manufacture of the articles and after the copper coating has been removed, and in those articles which do not require a protecting film of nickel this step may be entirely dispensed with. I find, however, that when the nickel is applied to the former or mold the deposit is thickest at the corners, which is very important in storage-battery work; whereas if the nickel is applied to the finished can it is likely to be thin and imperfect at the corners. After the copper coating has been removed, as explained, the article is trimmed on its upper edge ready to receive the cover or cap, and, if

desired, its sides may be provided with horizontal corrugations located within the edges of the can, so as to stiffen the same, as I describe in application for Letters Patent filed November 28, 1902, Serial No. 133,112. Finally the can or receptacle is nickel-plated on its outside, so as to prevent the same from oxidation, and, if desired, an additional coating of nickel may be applied to the inside thereof and welded thereto. The can or receptacle is now finished and is ready to receive the electrodes, after which the top or cover is soldered in place.

Cans made in this way can be manufactured very cheaply, they are of superior appearance, they are very strong and tough, they are free from pits or holes, they do away entirely with the necessity of using solder-joints, and they are well suited for the purpose for which they are designed. When articles of other forms or of different materials are made, the process will be modified as will suggest itself to persons skilled in the art.

Having now described my invention, what I claim as new therein, and desire to secure by Letters Patent, is as follows:

1. The process of making a storage-battery can or receptacle, which consists in coating a film of copper on a former of suitable shape, in plating a film of iron on the copper coating, and in removing the copper film, substantially as set forth.

2. The process of making hollow, seamless articles, which consists in coating a former with a wax-like material, in applying a conducting coating thereto, in electroplating a layer of copper on the conducting coating, in applying electrolytically a coating of iron to the copper deposit, in applying heat to melt the wax-like material and permit the deposited coating to be removed, and in finally separating the copper deposit from the iron, substantially as and for the purposes set forth.

3. The process of electrodepositing iron, which consists in placing a cathode in a bath suitable for the deposition of iron and which contains an iron anode and loose particles of foreign material of less specific gravity than said bath, passing a current through said anode, bath and cathode, and simultaneously causing the said cathode to be rubbed or scoured by said particles, whereby a continuous and even deposit of iron is obtained on said cathode, substantially as set forth.

4. The process of electrodepositing iron, which consists in placing a cathode in a bath suitable for the deposition of iron and which contains a suitable anode and particles of charcoal, passing a current through said anode, bath and cathode and simultaneously causing the said cathode to be rubbed or scoured by said particles, whereby a continuous and even deposit of iron is obtained on said cathode, substantially as set forth.

5. The process of electrodepositing iron,

- which consists in placing a cathode in a bath of ferrous ammonium sulfate containing a suitable anode and particles of charcoal, passing a current through said anode, bath and cathode, and simultaneously causing the cathode to be rubbed or scoured by said particles, whereby a continuous and even deposit of iron is obtained on said cathode, substantially as set forth.
6. The process of manufacturing steel, which consists in placing a cathode in a bath suitable for the deposition of iron and which contains an iron anode and particles of charcoal, passing a current through said anode, bath and cathode and simultaneously causing the cathode to be rubbed or scoured by said particles, whereby a continuous and even deposit of iron containing carbon is obtained on said cathode, and then removing the said deposit from the cathode and annealing it, substantially as set forth.
7. The process of manufacturing steel, which consists in electrodepositing iron upon a cathode whose active surface is in contact with particles of carbon, whereby a deposit of iron containing carbon is obtained, and then subjecting the said deposit to heat, substantially as set forth.

This specification signed and witnessed this 3d day of October, 1903.

THOMAS A. EDISON

Witnesses:

FRANK L. DYER,  
W. A. DOLAN.