

930,948.

F. A. EDISON.
APPARATUS FOR BURNING PORTLAND CEMENT.
APPLICATION FILED NOV. 26, 1906.

Patented Aug. 10, 1909.
2 SHEETS—SHEET 1.

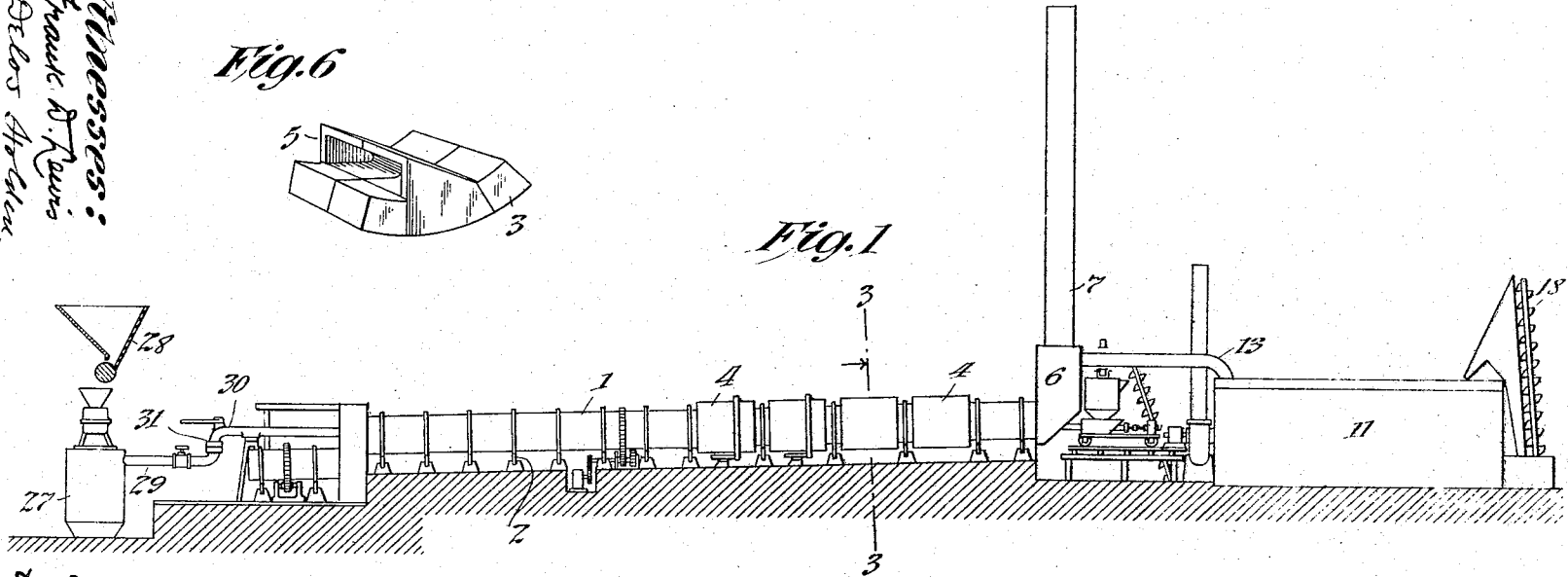

Fig. 6

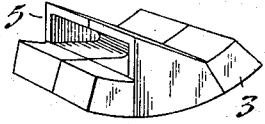

Fig. 1

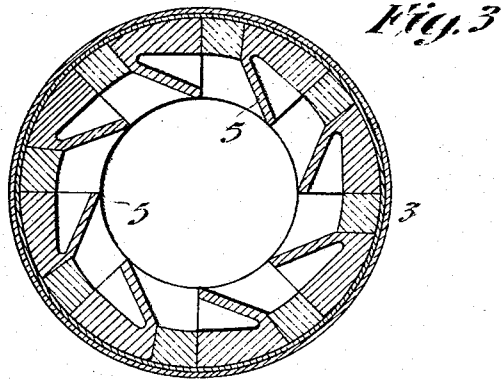

Fig. 3

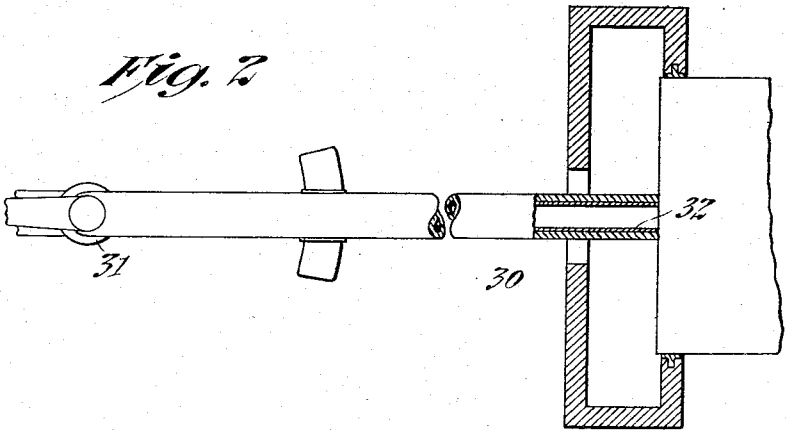

Fig. 2

Witnesses:
Frank D. Lewis
De los Angeles.

Inventor:
Thomas A. Edison
By Bruce K. Brown
Att'y.

930,948.

T. A. EDISON.
APPARATUS FOR BURNING PORTLAND CEMENT,
APPLICATION FILED NOV. 26, 1906.

Patented Aug. 10, 1909.

2 SHEETS—SHEET 2.

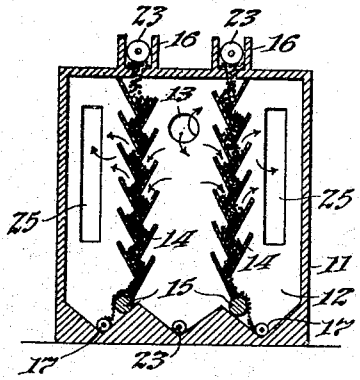

Fig. 5

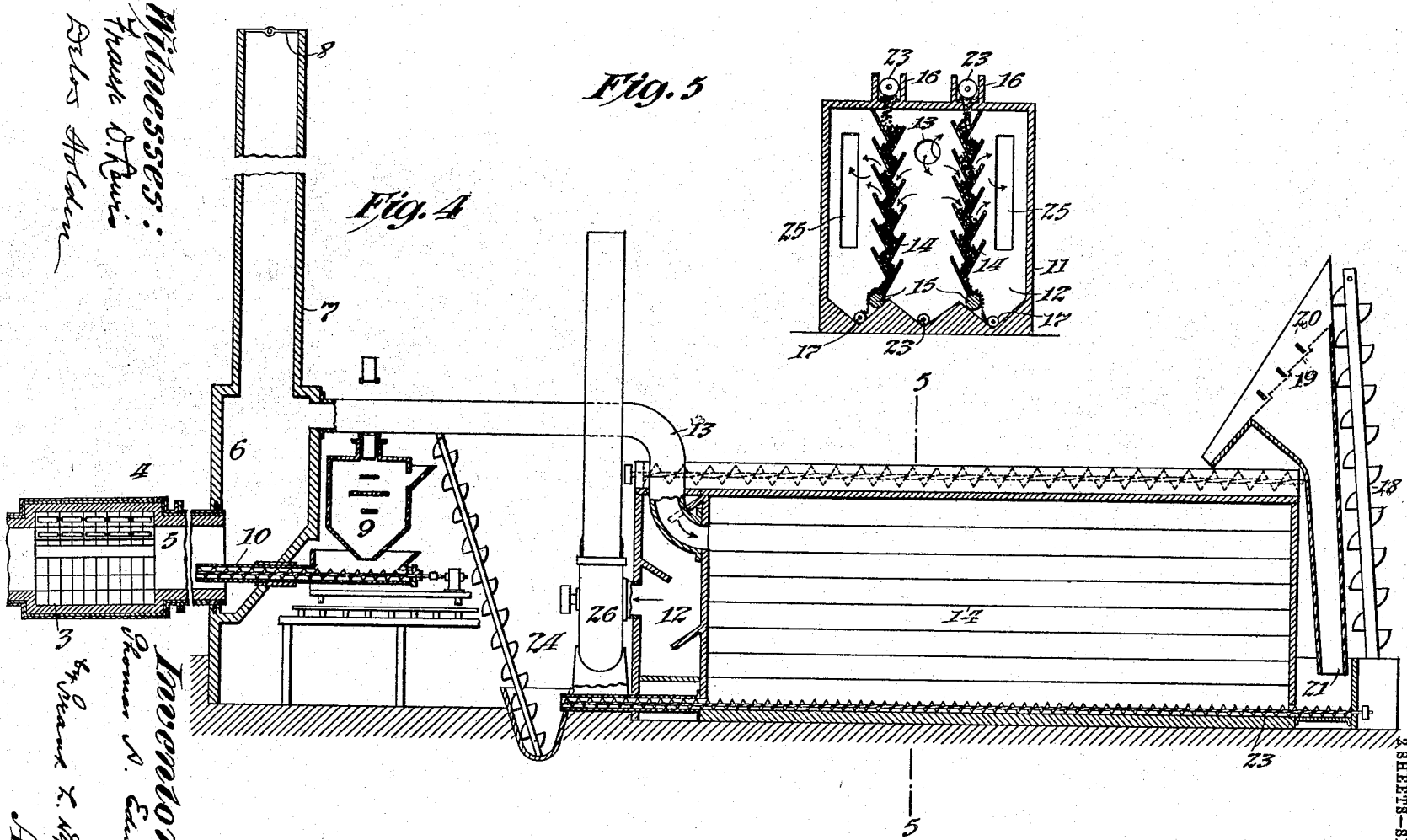

Fig. 4

Witnesses:
Frank D. Davis
Arthur H. Adams

Inventor:
Thomas A. Edison
by Stewart T. Hume
Atty.

UNITED STATES PATENT OFFICE.

THOMAS A. EDISON, OF LLEWELLYN PARK, ORANGE, NEW JERSEY.

APPARATUS FOR BURNING PORTLAND CEMENT.

No. 930,948.

Specification of Letters Patent.

Patented Aug. 10, 1909.

Application filed November 26, 1906. Serial No. 345,041.

To all whom it may concern:

Be it known that I, THOMAS ALVA EDISON, a citizen of the United States, residing at Llewellyn Park, Orange, county of Essex, and State of New Jersey, have invented certain new and useful Improvements in Apparatus for Burning Portland Cement, of which the following is a description.

My invention relates to an improved apparatus for burning Portland cement of the type employing a long rotary slightly inclined kiln, fired at the lower end and supplied with dry pulverized material or chalk at the upper end, the material passing slowly through the kiln as the latter is revolved, and being burned or clinkered in transit so that it leaves the lower end of the kiln in the form of hard clinker balls, which are ground to obtain the final product. Heretofore, the burning of Portland cement in apparatus of this type has been most successfully effected by the combustion of one or more streams of finely pulverized coal injected into the lower end of the kiln, the air to support combustion being generally drawn in through a cooling cylinder so as to abstract heat from the clinkered material.

It is a fact recognized by engineers that a rotary cement kiln is probably the most inefficient and wasteful industrial apparatus in use today, and its successful employment in this country is only possible because of the low price of coal and the comparatively high price commanded for the finished product. The principal cause for the inefficiency of a rotary cement kiln is that the body of material undergoing treatment occupies a small portion of the area of the kiln, so that enormous losses are incurred in the exit gases, which leave the kiln at a high temperature. Other losses are incurred by reason of the ineffective heating of the material, since practically only a small proportion of the surface of the load of material is subjected to the heat, even if the load is turned by projections from the lining, as heretofore proposed. Additional losses are also due to the dissipation of heat by conduction and radiation through and from the kiln walls. Furthermore, the gases derived from the combustion of pulverized coal are non-luminous and hence practically non-radiant, so that in passing practically unconfined through the tubular flue which the kiln presents, very poor conditions are offered for imparting heat to the material, except

in the lowermost part of the kiln where combustion takes place and the flame is luminous and can impart its heat to the material by radiation.

The fact that by the combustion of pulverized coal a luminous flame is obtained is the particular reason why this fuel has been used instead of other sources of heat, notwithstanding the cost of grinding the coal and the dangers incident thereto. It has been suggested that producer gas might be utilized in connection with a rotary cement kiln, but it was recognized that with the existing apparatus such a source of heat could not be effectively utilized, since the flame obtained by the combustion of producer gas would be substantially as non-luminous and non-radiant as that of a Bunsen burner. Hence it has been considered impossible to effectively use producer gas in a rotary cement kiln, notwithstanding the great advantages that would be derived therefrom in the saving of the cost of grinding and in the possibility of using sources of fuel of very poor quality.

In an application for Letters Patent, filed October 24, 1906, Serial No. 340,299, I disclose a cement burning apparatus, consisting essentially of a rotary cement kiln, the upper portion of which is equipped with wings or projections on the bore, whereby as the kiln is rotated the material in transit through the same will be showered crosswise so as to fill the bore of the kiln with a cloud of the fine material, representing as much as half of the entire load, and with such a kiln I have described the use of an improved settling chamber and filter by which I am enabled to effectively separate from the draft, all of the fine material blown out of the kiln therewith. By means of such an apparatus I am enabled to effect very considerable economies in the fuel, since conditions are presented which approximate somewhat the ideal conditions of a blast furnace the flame and the hot products of combustion being brought into direct contact with the fine material so as to heat the same by impingement, and the gases being also made luminous so as to impart heat by radiation throughout the greater part of the kiln, instead of radiation taking place only at the lower end where combustion occurs, as with the present forms of apparatus. I find that with an apparatus of this type, I can successfully make use of pro-

ducer gas, natural gas, and other gaseous sources of heat which have been heretofore impracticable in the art, owing to the non-luminous character of the flame derived therefrom, for the reason that the flame and gaseous products therefrom will encounter the material directly as it is showered cross-wise through the kiln so as to heat the same by direct impingement, while at the same time, the flame and gaseous products will be made luminous, so as to impart its heat to the bulk of material by radiation as well as by contact. At the same time, the provision of a settling chamber and filter, as described, prevents losses due to the carrying off of material with the draft.

In order that the invention may be better understood, attention is directed to the accompanying drawings, forming part of this specification, and in which—

Figure 1, is a side elevation of a cement burning apparatus of the type disclosed in my said application, and illustrating the employment of a gas producer in combination therewith; Fig. 2, an enlarged sectional view, showing a part of the lower end of the kiln and illustrating the burner; Fig. 3, a section on the line 3—3 of Fig. 1, illustrating the inclined wings used on the interior of the kiln for showering the material cross-wise through the same; Fig. 4, a longitudinal sectional view on an enlarged scale, showing the upper end of the kiln and filter; Fig. 5, a section on the line 5—5 of Fig. 4, and, Fig. 6, a separate perspective view, showing the preferred arrangement for providing the showering wings.

In all of the above views, corresponding parts are represented by the same numerals of reference.

The kiln 1, as heretofore, is made of cast iron sections, the total length being preferably in the neighborhood of 150 feet and its internal diameter about five or five and one-half feet. The kiln is supported on rollers 2, and is maintained at a slight angle so as to cause the fine material or chalk to progress slowly along the same as the kiln is rotated. The firebrick lining 3 is of the usual construction and protects the cast-iron walls from the heat. The upper portion of the kiln, say, for a length of about fifty feet, is formed of sections 4—4, which are larger in diameter than the main portion of the kiln, and within these enlarged portions I provide inclined wings 5 (see Fig. 3) arranged to form pockets for carrying up the material and showering it diametrically across the kiln, as will be understood, whereby the material will be constantly falling off of the wings until the wings have passed considerably beyond the vertical line of the kiln, as shown in said figure, so as to maintain a cloud or shower of the fine dust filling substantially the entire bore of the kiln.

As shown in Fig. 6, the wings 5 are preferably formed integrally with certain of the firebrick blocks forming the lining, each wing being composed of two blocks arranged side by side, so that the wings constitute pockets or recesses in which the material will accumulate as the kiln rotates, and out of which the material will be showered, as explained. In this way, no unoccupied space is offered through which the flame or products of combustion may pass in a non-luminous condition, but on the other hand, the flame, (if sufficiently extended) and products of combustion will of necessity be brought into direct contact with the material. The inner edges of the wings 5 extend substantially in line with the bore of the main portion of the kiln, so that in each of the outer sections 4, additional space is provided in which a considerable load of material may accumulate to more effectively abstract heat from the burning gas and products of combustion therefrom. By providing additional spaces in this way within the kiln, it is possible to increase the load of chalk which may be showered by the wings 5, so that a large part of the load may be maintained at all times in the direct path of the burning gas and the products of combustion therefrom. In this way, the gases are made luminous, as I will explain, so that the heat therefrom will be absorbed by radiation, as well as by direct contact. The upper end of the kiln opens into a chamber 6, from which extends a stack 7, having a damper 8 therein, so that if desired, the products of combustion may pass up through the stack. The stack may also be used when the kiln is first fired, or in case of accident to the filtering apparatus. The pulverulent material or chalk is supplied to a bin 9 and is fed therefrom into the upper end of the kiln by a screw conveyer 10, as heretofore. Adjacent to the upper end of the kiln, is a settling chamber 11, comprising generally a rectangular structure, whose walls may be conveniently built of firebrick or cement. Near the front of the filter is a wall 12, through which passes a flue 13, connected to the chamber 6, whereby the products of combustion, etc. from the kiln, will be directed into the central part of the filter. Extending longitudinally of the filter between the wall 12 and the rear wall are two vertical rows of plates 14, inclined at a very acute angle and made preferably of firebrick or cement. I supply to the two sets of plates a load of relatively coarse material, constituting a screening or filtering medium, and which may be composed of coarse sand or gravel or coarsely ground cement rock, the particles ranging preferably from $\frac{1}{16}$ to $\frac{1}{8}$ of an inch in size, the thickness of the body of coarse material being about $1\frac{1}{2}$ inches. The filtering material will accumulate between

the inclined shelves, so as to form a substantially vertical filter, presenting innumerable fine interstices and tortuous channels, through which the draft may pass and in which any fine dust or chalk may settle. The filtering material in each filtering partition is kept very slowly in movement by means of a roller feed 15, operated in any suitable way, fresh material being supplied from an extended trough 16, above each filter. The coarse granular material is drawn off at the bottom of each partition and, carrying with it the load of separated chalk or dust, is deposited by the roller feed 15 onto a conveyer 17 of any suitable type, by which it is conducted to an elevator 18, (see Fig. 4) and is elevated by the latter and deposited upon a series of screens 19, provided with checking shelves 20, so as to prevent the material from passing too rapidly over the screens. By means of the screens 19, the fine dust or chalk will fall into a chute 21, while the coarse material will be returned to the hoppers 16 and be distributed through the latter by the conveyers 22. From the chute 21, the fine chalk is deposited into the path of the conveyer 23 which extends longitudinally of the main portion of the filter between the two filtering partitions and leads to an elevator 24, by which the fine material will be conducted to the bin 9, as shown. The main portion of the filter is formed with an inclined bottom, as shown, and constitutes a settling chamber, which is of such a size relatively to the area of the kiln that the velocity of the products of combustion is materially arrested, so that the greater proportion of dust or chalk carried therewith will deposit by gravity in the settling chamber and be carried off by the conveyer 23 and elevator 24 to the bin 9. The draft, after passing through the filtering walls, escapes through two vertical openings 25, in the wall 12, and is sucked out from the front of the filter by a fan 26, operated from any source of power, preferably an electric motor controlled by the kiln man at the front of the kiln. By creating a draft within the kiln through the agency of a fan operated by a readily controllable motor, the draft is under much better control than when created by the stack, as is now the practice, and it may be quickly varied by the kiln man to meet any changing conditions within the kiln.

Arranged adjacent to the lower end of the kiln is a gas producer 27 of any suitable type, located beneath a bin 28, which may contain coal of poor quality, since producer gas can be generated therefrom of sufficient purity for my purpose. It is, in fact, perfectly feasible by using a gas producer to effectively utilize coal of such poor quality that it could not possibly be employed in the old way. Leading out from the producer

27 is a gas pipe 29, from which leads a nozzle 30 mounted on a swiveled joint 31, so that the nozzle may be directed into the kiln at any desired angle. The gas pipe 29 and nozzle 30 are preferably provided with a protecting lining 32 made of firebrick or other vitreous material so as to protect the metal from the heat of the gas, or if desired the pipe and nozzle may be made of a suitable resistant material that will not be affected thereby.

Although I describe and illustrate a gas producer as a suitable source of gas supply, it will be understood that natural gas may be employed and that other combustible gas may be derived from other sources and by other means.

In operation, the fine material or chalk is fed to the kiln in the usual way, and in passing slowly through the same, will enter the pockets formed by the enlarged sections 4 of the kiln, so as to accumulate therein in large loads. Within these pockets, the material will be engaged by the wings 5, and carried upwardly, so as to be showered or scattered diametrically across the kiln and directly across the draft. By properly proportioning the angle of the wings 5, this showering of the material can be adjusted so as to take place even after the wings have passed the central vertical line of the kiln, whereby the bore of the kiln will be substantially occupied with a cloud of fine particles falling through the same and across the path of the draft. It is not absolutely necessary to employ the enlarged sections, since properly arranged and shaped projections might be carried in the lining of the kiln, having substantially a continuous bore, but such enlarged sections are desirable as they permit large loads of the fine material to accumulate therein, and thus allow a much larger mass of material to be presented to the direct effect of the flame and products of combustion. By thus showering the chalk across the kiln, it will be very perfectly acted upon by the flame and products of combustion and nearly all of the heat will be absorbed by the material, so that the operation will be very economical. Furthermore, by impinging the flame into a mass or cloud of fine material, as explained, the individual particles of chalk will be heated, so that the flame will become luminous and highly radiant, and heat therefrom will be absorbed by radiation. From the kiln, the draft carrying with it, a relatively large proportion of fine dust, enters the settling chamber between the two filter walls. The area of the settling chamber is so great that the velocity of the draft will be greatly reduced, so that a large portion of the chalk will be deposited by gravity in the settling chamber, and will be carried to the bin 9 by the conveyer 23 and elevator 24. From the settling cham-

ber, the products of combustion pass slowly through the channels presented by the granular filtering material carried by the inclined plates 13, the area presented by the filtering material being very extensive and permitting the products of combustion to seep relatively slowly through the filtering walls. By thus causing the products of combustion to pass slowly through the fine channels or pores presented within the filtering material, any excessively fine dust-like particles carried by the draft and which were not deposited in the settling chamber, will be effectively separated and retained within the filtering material on account of the slow movement of the gaseous currents in the channels, and also because the channels are so tortuous that the dust particles in many cases would have to be lifted up against gravity, which the slow movement of the gaseous currents is unable to effect. Preferably, I maintain the load of coarse particles in constant, but very slow, movement, so that the filtering body is constantly replenished, while at the same time, its porosity remains unchanged. A movement sufficient to effect a complete change of the filtering walls in one hour will be sufficiently rapid for the purpose. Although the filtering material is thus in constant movement, the resistance offered by the filtering walls remains constant, so that the draft within the kiln will be always maintained in the most effective condition, without being subjected to objectionable fluctuations. As the load of coarse filtering material, (carrying with it the fine particles separated thereby) is fed from the two filtering walls by the roller feeds 15, it will be returned to the screens 20 by the conveyers 17 and elevators 18. By means of these screens the very fine particles will be separated and will be conducted by the chute 21 to the conveyer 23 and thence returned to the bin 9, while the coarse filtering material will be returned again to the trough 16 and by means of the conveyers 22 will be distributed to the upper end of the filter walls, so as to once more pass in transit slowly over the inclined shelves 14.

Having now described my invention, what I claim as new and desire to secure by Letters Patent, is as follows:

1. In cement burning apparatus, the combination with a rotary kiln, means for introducing pulverized material therein at the upper end thereof, means for showering the material diametrically across the kiln during its passage therethrough to the lower end thereof, and a filter connected with the discharge from the kiln, and presenting at all times a constant porosity, of a source of gas supply connected with the lower end of the kiln, substantially as and for the purposes set forth.

2. In cement burning apparatus, the combination with a rotary kiln, means for introducing pulverized material therein, means for showering the material diametrically across the kiln and a filter connected with the discharge from the kiln and presenting at all times a constant porosity, of a gas producer connected with the lower end of the kiln, substantially as and for the purposes set forth.

3. In cement burning apparatus, the combination with a rotary kiln, means for introducing pulverized material therein, means for showering the material diametrically across the kiln, a settling chamber connected with the discharge from the kiln and of large size to permit the velocity of the products of combustion therefrom to be very greatly reduced, so as to effect a separation by gravity of the solid or dust-like particles, and a filter adjacent to the settling chamber and through which the products of combustion pass from the settling chamber to effect a final separation of the finer solid or dust-like particles carried in suspension, said filter presenting at all times a constant porosity, of a source of gas supply connected with the lower end of the kiln, substantially as and for the purposes set forth.

4. In cement burning apparatus, the combination with a rotary kiln, means for introducing pulverized material therein, means for showering the material diametrically across the kiln, a settling chamber connected with the discharge from the kiln, and of large size to permit the velocity of the products of combustion therefrom to be very greatly reduced, so as to effect a separation by gravity of the solid or dust-like particles, and a filter adjacent to the settling chamber and through which the products of combustion pass from the settling chamber to effect a final separation of the finer solid or dust-like particles carried in suspension, said filter presenting at all times a constant porosity, of a gas producer connected at the lower end of the kiln, substantially as and for the purposes set forth.

5. In cement burning apparatus, the combination with a rotary kiln, means for introducing pulverized material therein, means for showering the material diametrically across the kiln and a filter connected with the discharge from the kiln and presenting a filtering wall or partition of granular material, of a source of gas supply connected with the lower end of the kiln, substantially as and for the purposes set forth.

6. In cement burning apparatus, the combination with a rotary kiln, means for introducing pulverized material therein, means for showering the material diametrically across the kiln, a filter connected with the discharge from the kiln, and presenting a filtering wall or partition of granular ma-

terial, and means for effecting a movement of the filtering material, of a source of gas supply connected with the lower end of the kiln, substantially as and for the purposes set forth.

7. In cement burning apparatus, the combination with a rotary kiln, means for introducing pulverized material therein, means for showering the material diametrically across the kiln, and a settling chamber connected with the kiln, a part of said settling chamber being formed of a wall of granular material, constituting the filtering medium, of a source of gas supply connected with the lower end of the kiln, substantially as and for the purposes set forth.

8. In cement burning apparatus, the combination with a rotary kiln, means for introducing pulverulent material therein, means for showering the material diametrically across the kiln, and a settling chamber connected with the discharge from the kiln, the opposing walls of said settling chamber being formed of loose granular material and each wall constituting a filter, of a source of gas supply connected with the lower end of the kiln, substantially as and for the purposes set forth.

9. In a cement burning apparatus, the combination with a rotary kiln, of means for introducing pulverized material therein at the upper end thereof, means for showering the material across the kiln, during the passage of the material through the portion of the kiln through which the material is first progressed, said showering means being so constructed that the material is showered thereby across substantially the whole diameter of the bore of the kiln, and a source of gas supply connected with the lower end of the kiln, substantially as set forth.

10. In a cement burning apparatus, the combination with a rotary kiln, of means for introducing pulverized material therein at the upper end thereof, means for showering the material across the kiln, during the passage of the material through the portion of the kiln through which the material is first progressed, said showering means being so constructed that the material is showered thereby across substantially the whole diameter of the bore of the kiln, a filter connected with the discharge from the kiln, and a source of gas supply connected with the lower end of the kiln, substantially as set forth.

11. In a cement burning apparatus, a rotary kiln therefor, provided with a lining

formed of blocks of refractory material, a portion of said blocks presenting integral pockets inclined at such an angle that in the revolution of the kiln, the material contained in said pockets will be showered across substantially the whole diameter of the bore of the kiln, substantially as set forth.

12. In cement burning apparatus, a rotary kiln therefor, provided with a lining formed of blocks of refractory material, a portion of said blocks presenting integral pockets comprising side walls and an inclined front wall, as and for the purposes set forth.

13. In cement burning apparatus, a rotary kiln therefor, provided with a lining formed of blocks of refractory material, pairs of said blocks presenting conjointly inclined inclosing wings or pockets, substantially as and for the purposes set forth.

14. As a new manufacture, a block for the lining of a rotary cement kiln, presenting a portion of an inclosed pocket, the bottom of which constitutes an inclined wing, as and for the purposes set forth.

15. In cement burning apparatus, the combination with a rotary cement kiln, and a bin for supplying pulverized material thereto, of a filter connected with the discharge from the kiln and through which the products of combustion are caused to pass, means for removing from the filter the fine material accumulated thereby, and means for returning such fine material to the bin, as and for the purposes set forth.

16. In cement burning apparatus, the combination with a rotary cement kiln, and a bin for supplying pulverized material thereto, of a settling chamber to which the products of combustion from the kiln are directed and in which a portion of the solid matter carried thereby will be deposited by gravity, means for returning the solid material to the bin, a filter through which the products of combustion pass after leaving the settling chamber, and in which a further deposit of solid material takes place, means for removing the solid material from the filter, and means for returning such solid material to the bin, substantially as and for purposes set forth.

This specification signed and witnessed this 16th day of November, 1906.

THOMAS A. EDISON.

Witnesses:

FRANK L. DYER,
ANNA R. KLEHM.