

(No Model.)

T. A. EDISON.

REGULATOR FOR DYNAMO ELECTRIC MACHINES.

No. 265,780.

Patented Oct. 10, 1882.

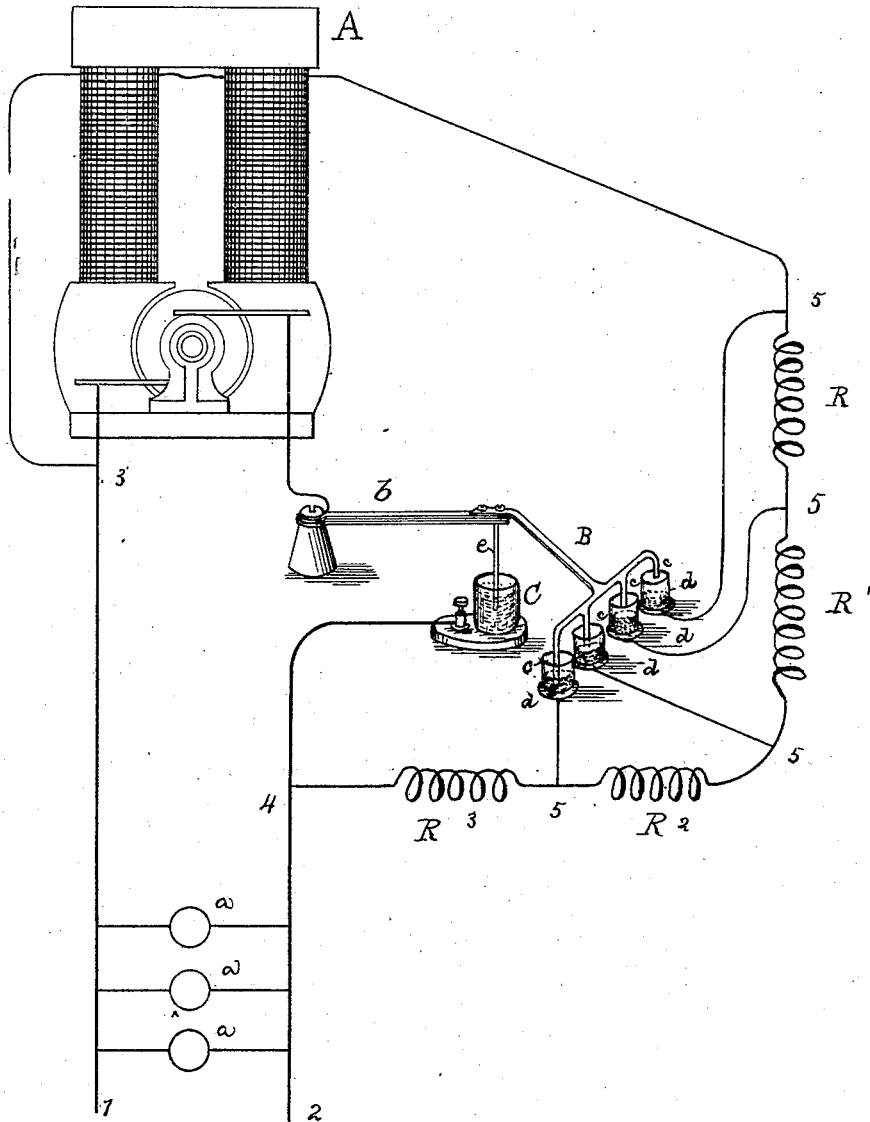

WITNESSES:

E. C. Rowland,
W. Wheeler

INVENTOR:

Thomas A. Edison,
By Rich^d. N. Dyer,
Att'y.

UNITED STATES PATENT OFFICE.

THOMAS A. EDISON, OF MENLO PARK, NEW JERSEY.

REGULATOR FOR DYNAMO-ELECTRIC MACHINES.

SPECIFICATION forming part of Letters Patent No. 265,780, dated October 10, 1882.

Application filed August 7, 1882. (No model.)

To all whom it may concern:

Be it known that I, THOMAS A. EDISON, of Menlo Park, in the county of Middlesex and State of New Jersey, have invented a new and useful Improvement in Regulating the Generative Capacity of Dynamo or Magneto Electric Machines, (Case No. 402;) and I do hereby declare that the following is a full and exact description of the same, reference being had to the accompanying drawing, and to the letters of reference marked thereon.

The object of my invention is to produce means for regulating the generation of current by a dynamo or magneto electric machine supplying a multiple-arc system of electrical distribution which shall be caused to operate by the thermal effect of the current generated. To accomplish this I place in one of the conductors of the main circuit a metal strip or bar which will be heated by the passage of current through it. This bar is so placed that its expansion and contraction, caused by variations in such heating, will cause the opening and closing of circuits, such opening and closing causing variations in the current energizing the field-magnet of the generator, the coils of which magnet are preferably included in a multiple-arc circuit or circuits from the main conductors, though, if desired, the magnet may be energized from any external source.

A convenient form of my invention is one in which a double strip composed of two metals of different degrees of expansion is placed in the main circuit and held rigidly at one end, but free at the other, the circuit being completed at the free end by means of a point dipping into a mercury-cup. An arm is attached to the free end of the strip, which arm carries a number of contact-points, each dipping into a mercury-cup, the contact-points being of different lengths, or the mercury of different heights, in order that successive contacts may be made and broken. In the multiple-arc circuit which includes the field-magnet is placed a series of resistances, around each of which is formed a shunt including one of the mercury-cups. When the number of lamps or translating devices in multiple-arc on the main conductor is increased the increase of current

causes the heating of the compound bar, the unequal expansion of which causes said bar to bend downward, which lowers the end of the arm carrying the contact-points, which, as they successively dip into the mercury-cups, cause the closing of the shunts around the resistances in the field, and thus increase the generative capacity of the machine. A decrease in the number of translating devices causes a contrary effect, the shunt-circuits being opened and the resistances again placed in circuit.

Instead of opening and closing circuits around resistances, this arrangement may be used to open and close new circuits through the coils of the field-magnet, as shown in Case No. 68,618, of even date herewith, such coils being for this purpose divided into a number of separate sections or bobbins each included in a different circuit.

My invention may be more readily understood by reference to the annexed drawing, which is a diagrammatic view, illustrating the arrangement just described.

A is a dynamo electric machine, and 1 2 the main conductors leading therefrom, on which are placed in multiple-arc circuits lamps or other translating devices, *a a a*.

3 4 is a multiple-arc circuit energizing the field-magnet of the generator and containing resistances $R R' R^2 R^3$. In main conductor 1 is placed the compound strip *b*, at whose free end the point *e* dips in the mercury-cup *C*, and which has secured to it the arm *B*, carrying contact-points *c c*, each dipping into a mercury-cup, *d*. Wires 5 5 from the field-circuit 3 4 form shunts around the resistances $R R' R^2 R^3$.

The operation of these devices is as above described.

What I claim is—

1. The combination, with a dynamo or magneto electric machine and translating devices arranged in multiple arc, of a resistance in the field-circuit, mercury-cups connected with such resistance at intervals, and a thermostatic device in the main circuit carrying points which dip into said mercury-cups in succession, substantially as set forth.

2. The combination of a multiple-arc circuit including the coils of the field-magnet of a dy-

namo-electric machine, a multiple-arc circuit including the armature of said machine, multiple-arc circuits containing lamps or other translating devices, (all such multiple-arc circuits being derived from the same main conductors,) a resistance in the field-circuit, mercury-cups connected with such resistance at intervals, and a thermostatic device in the main circuit carrying points which dip into said

mercury-cups in succession, substantially as is set forth.

This specification signed and witnessed this 28th day of February, 1882.

THOMAS A. EDISON.

Witnesses:

H. W. SEELY,

THOMAS JOHNSTON.