

(No Model.)

T. A. EDISON.

DYNAMO OR MAGNETO ELECTRIC MACHINE.

No. 268,205.

Fig. 1.

Patented Nov. 28, 1882.

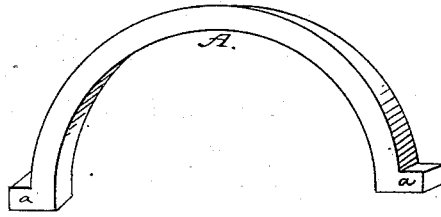

Fig. 2.

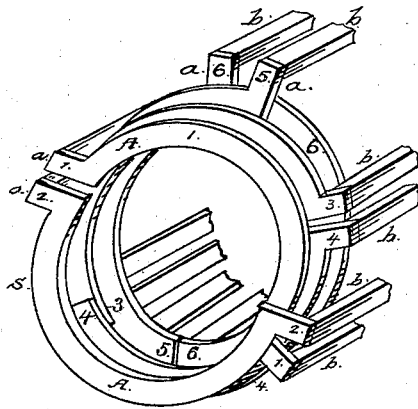

Fig. 3.

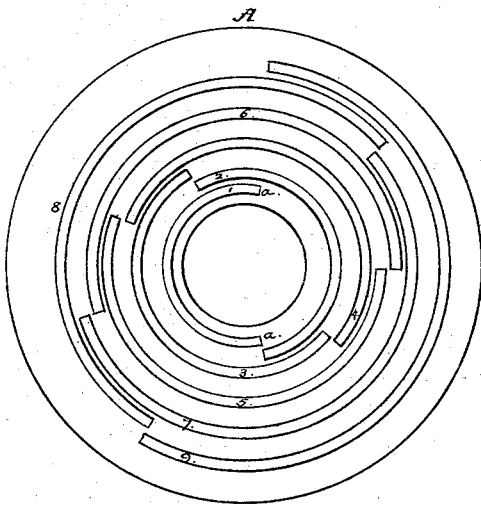
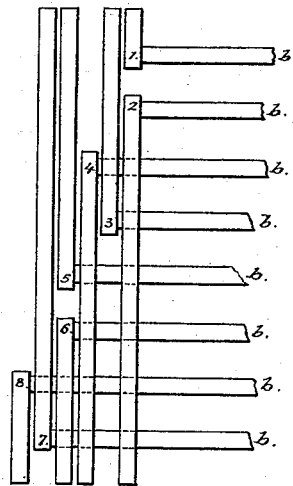

Fig. 4.



Attest;
F. W. Howard
A. B. Miller

Inventor;
T. A. Edison per
A. B. Miller atty

UNITED STATES PATENT OFFICE.

THOMAS A. EDISON, OF MENLO PARK, NEW JERSEY.

DYNAMO OR MAGNETO ELECTRIC MACHINE.

SPECIFICATION forming part of Letters Patent No. 268,205, dated November 28, 1882.

Application filed May 17, 1882. (No model.)

To all whom it may concern:

Be it known that I, THOMAS A. EDISON, of Menlo Park, in the county of Middlesex and State of New Jersey, have invented a new and useful Improvement in Dynamo or Magneto Electric Machines, (Case No. 416;) and I do hereby declare that the following is a full and exact description of the same, reference being had to the accompanying drawings, and to the letters of reference marked thereon.

In that class of magneto or dynamo electric machines in which the revolving armature is composed of a cylindrical core whose surface is partially or entirely covered with coils wound parallel to the axis of the armature the coils cross each other at the ends, so that there is a large mass of wire upon the ends useless for the purposes of generation, while interposing unnecessary internal resistance in the machine, and at the same time being in position for excessive accumulation of heat. These masses of wire, crossing each other at the ends, render repairs to any coil exceedingly difficult, for the repair of any one coil involves the unwinding of such coils as may overlap it upon the ends. A plan for remedying these defects forms the subject-matter of United States Letters Patent No. 242,898, granted me June 14, 1881. In that invention the end crossings of wire upon the armature were replaced by radial metal plates, appropriate radial plates being connected in couples or pairs by circular metallic conductors.

The object of the invention in this case is to still further simplify the construction of the armature, and it is in substance an improvement upon the patent noted.

It consists in such construction and arrangement of the circular joining-conductors that the radial plates may be dispensed with and the connection of proper inductive portions into pairs or loops be made by the circular joining-conductors themselves. This is illustrated in the accompanying drawings, in which—

Figure 1 is a view of a single circular joining-conductor; Fig. 2, a perspective showing the arrangement of the circular joining-conductors and inductive bars, strips, or wires; Fig. 3, a diagrammatic plan; and Fig. 4, a side

view, showing the relative arrangement of the circular joining-conductors to each other.

Figs. 2, 3, and 4 represent the non-commutating end of the armature, and A, in full lines in Fig. 1, one of the circular joining-conductors. As in the case of the patent noted, these circular joining-conductors are a little more than half a circle, (or, if an oval or other shape be used, of little more than half its circumference,) and are provided with lugs *a a*. The requirement as to shape or form is simply that they be of such shape or form as to readily pass around the central shaft or axis of the armature. They may be formed of bars similar in size to the inductive portion of the armature, or they may be made of flat strips. They are secured upon an insulating-base upon the end of the armature-core, one upon the other, and are also effectually insulated from each other, and they are arranged so that the members of each pair overlap at one end and do not meet at the other, and, taking any point as the initial point, they alternately overlap and alternately do not quite meet. In Fig. 2, for instance, starting at S and going to the right, 1 2 do not quite meet, 5 6 overlap, 3 4 do not meet, 1 2 overlap, 5 6 do not meet, and 3 4 overlap. This probably is more apparent in Fig. 3, where nine are shown; but it is to be remembered that preferably the circular joining-conductors are to be placed one upon the other instead of concentrically. To the lugs *a a* are secured the inductive parts *b b b*—bars in this instance—the overlapping at one end and the non-meeting at the other of a pair of joining-conductors insuring the union into a pair, loop, or couple by each joining-conductor of opposite inductive portions, while at the same time uniformity in the distribution of the mass of the joining-conductors is secured, as upon every part of the end there is an equal thickness of metal, as may readily be seen from inspection of Fig. 3. Upon the commutating end the lugs of the conducting-plates are joined to strips leading to the commutator, so as to form the connections shown in the patent noted, all the inductive portion being thereby retained in circuit. While the connecting-plates are shown as circular, it is evident that this mere shape may be varied, such a shape being retained as

will give a proper concavity for passing around the shaft.

What I claim is—

1. In a dynamo or magneto electric machine, an armature having its ends formed of strips or pieces connecting the inductive portions into pairs or loops, and cut or shaped to pass partially around the axis of the armature, substantially as set forth.

2. In a magneto or dynamo electric machine, an armature having the strips or pieces connecting the inductive portions into pairs or loops piled upon but insulated from each other, each of said strips or pieces partially encircling the armature-shaft, substantially as set forth.

3. In the armature of a dynamo or magneto

electric machine, the combination, with each loop or couple of the inductive portion, of a strip or piece formed or shaped to pass partially around the axis upon the end of the armature, substantially as set forth.

4. In the armature of a dynamo or magneto electric machine, the combination, with the inductive portions, of the cross connecting strips or pieces alternately overlapping and not meeting, substantially as set forth.

This specification signed and witnessed this 1st day of May, 1882.

THOMAS A. EDISON.

Witnesses:

H. W. SEELY,

P. B. WILBER.