

(No Model.)

T. A. EDISON.

COMMUTATOR FOR DYNAMO ELECTRIC MACHINES.

No. 328,572.

Patented Oct. 20, 1885.

Fig. 1.

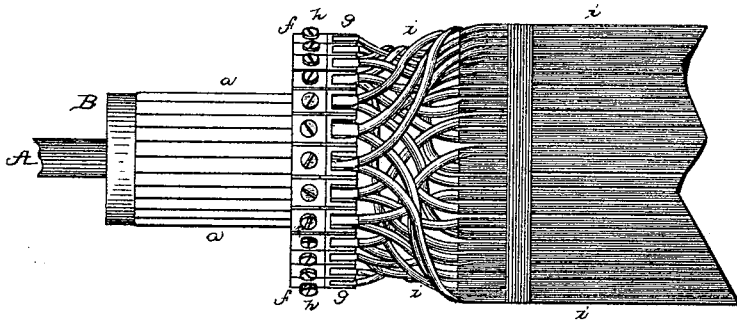

Fig. 2.

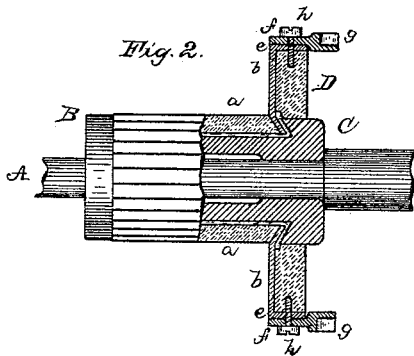

Fig. 3.

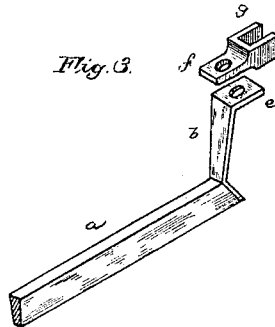
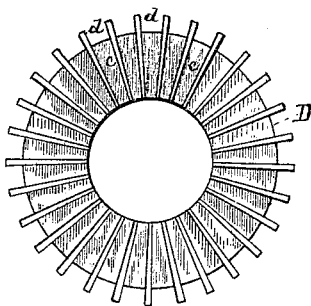

Fig. 4.



ATTEST:

*E. C. Rowland*

*W. W. Deely*

INVENTOR:

*Thomas A. Edison,*

*By Rich. T. Dyer,*  
*Atty.*

# UNITED STATES PATENT OFFICE.

THOMAS A. EDISON, OF MENLO PARK, NEW JERSEY.

## COMMUTATOR FOR DYNAMO-ELECTRIC MACHINES.

SPECIFICATION forming part of Letters Patent No. 328,572, dated October 20, 1885.

Application filed June 29, 1883. Serial No. 99,556. (No model.)

*To all whom it may concern:*

Be it known that I, THOMAS A. EDISON, of Menlo Park, in the county of Middlesex and State of New Jersey, have invented a new and useful Improvement in Dynamo-Electric Machines, (Case No. 580,) of which the following is a specification.

The object of this invention is to provide secure, good, and durable connections between the coils upon the armature of a dynamo-electric machine and the conducting-strips upon the commutator of the machine, which, while durable, secure, and effective, both mechanically and electrically, shall be removable, so that the commutator can be removed when worn out without any melting of solder; and my invention consists in the novel devices and combinations of devices employed by me in accomplishing this object, as hereinafter described and claimed.

My invention is illustrated in the annexed drawings, in which Figure 1 is a view in elevation of the commutator and the end of the armature of a dynamo-electric machine, showing the connecting devices; Fig. 2, a sectional view of the connecting devices and a portion of the commutator; Fig. 3, an enlarged perspective view of the connections to one commutator-bar, and Fig. 4 an elevation of the insulating-disk which supports and separates the connections.

A is the armature-shaft of the machine, and B is the commutator, consisting of an inner cylinder, C, provided with grooves, in which are placed the commutator-bars *a a*, separated from each other and from the cylinder by mica insulation, as set forth in another application made by me. The inner ends of these bars are beveled, as shown, and to these beveled ends are brazed the metal strips *b b*.

A disk, D, of insulating material, preferably vulcanized fiber, is placed upon the inner end of cylinder C, and serves to support all the connecting devices. Said disk is provided with grooves *e* in its face and grooves *d* in its periphery. In the face-grooves *e* are placed the strips *b*, which are thus held securely and insulated from each other. Their ends also are well secured, being turned obliquely and brazed between the beveled ends of the commutator-bars *a* and the beveled ends

of the grooves upon the cylinder C. The ends of the strips *b* are turned at right angles, and the bent portions *e* are inserted in the grooves *d* in the periphery of the disk D.

The intermediate connecting-pieces each consist of a flat portion, *f*, which is placed upon the part *e* in the groove *d*, and a box or cup, *g*, or other device capable of holding solder, into which terminal of the armature-coils are brought and soldered. The contacting surfaces of *e* and *f* are gold-plated, to make good electrical connection, and the two pieces are secured together by screws *h*, which enter the fiber disk D. These screws are preferably of iron or steel, and are also plated with the same metal as the other contact-surfaces.

The wire coils *i i* are wound longitudinally upon the armature. Each coil is composed of a number of wires. The end of a coil is brought to a box, *g*, from one side of the armature, and the opposite end of the coil next in position is brought from the other side to the same box. The first end of said next coil is brought to the next box, and the opposite end of the coil next to this is brought to the same box, and so on. Thus all the coils are connected longitudinally together, forming a single continuous coil, connected at intervals to the commutator-strips *a*. The two ends brought into a box are securely soldered therein, a good electrical and mechanical connection being thus provided.

To remove the commutator-cylinder, the screws *h* are withdrawn, when the cylinder and connecting-strips can be withdrawn from the shaft without disturbing the armature-connections. A new cylinder can then be placed on the shaft and the connecting-strips screwed together.

It will be seen that all the connections made from the coils to the commutator-strips are good and secure, and that all the parts are rigidly held in position.

What I claim is—

1. The combination, with the conducting-strips rising from the commutator-bars and turned at right angles, of the connecting-pieces removably secured thereto and permanently secured to the armature-coils, substantially as set forth.

2. The intermediate connecting-pieces, pro-

vided with boxes or cups, in which the armature-conductors are secured, substantially as set forth.

5 3. The combination, with the commutator-bars placed in grooves in a cylinder, of the conducting-strips secured between said bars and the ends of said grooves, substantially as set forth.

10 4. The combination, with the commutator-bars having beveled ends, and the beveled ends of the grooves, of the oblique ends of the conducting-strips secured between them, substantially as set forth.

15 5. The combination, with the strips rising from the commutator-bars, of the insulating-disk having grooves in its face, in which said strips are held, substantially as set forth.

20 6. The combination, with the devices connecting the armature-coils with the strips rising from the commutator-bars, of the insulating-disk having grooves in its periphery, in

which such devices are held, substantially as set forth.

7. The combination, with devices, substantially such as described, connecting the armature-coils with the commutator-bars, of the insulating-disk having face grooves and edge grooves, in which such devices are held, substantially as set forth. 25

8. The combination, with the conducting-strips rising from the commutator-bars and turned at right angles, of the intermediate connecting-pieces attached to said rising strips, said intermediate pieces being provided with boxes or cups, in which the armature-coils are secured, substantially as set forth. 30 35

This specification signed and witnessed this 25th day of June, 1883.

THOS. A. EDISON.

Witnesses:

H. W. SEELY,  
EDWARD H. PYATT.