

(No Model.)

T. A. EDISON.
ELECTRIC LIGHTING SYSTEM.

No. 439,392.

Patented Oct. 28, 1890.

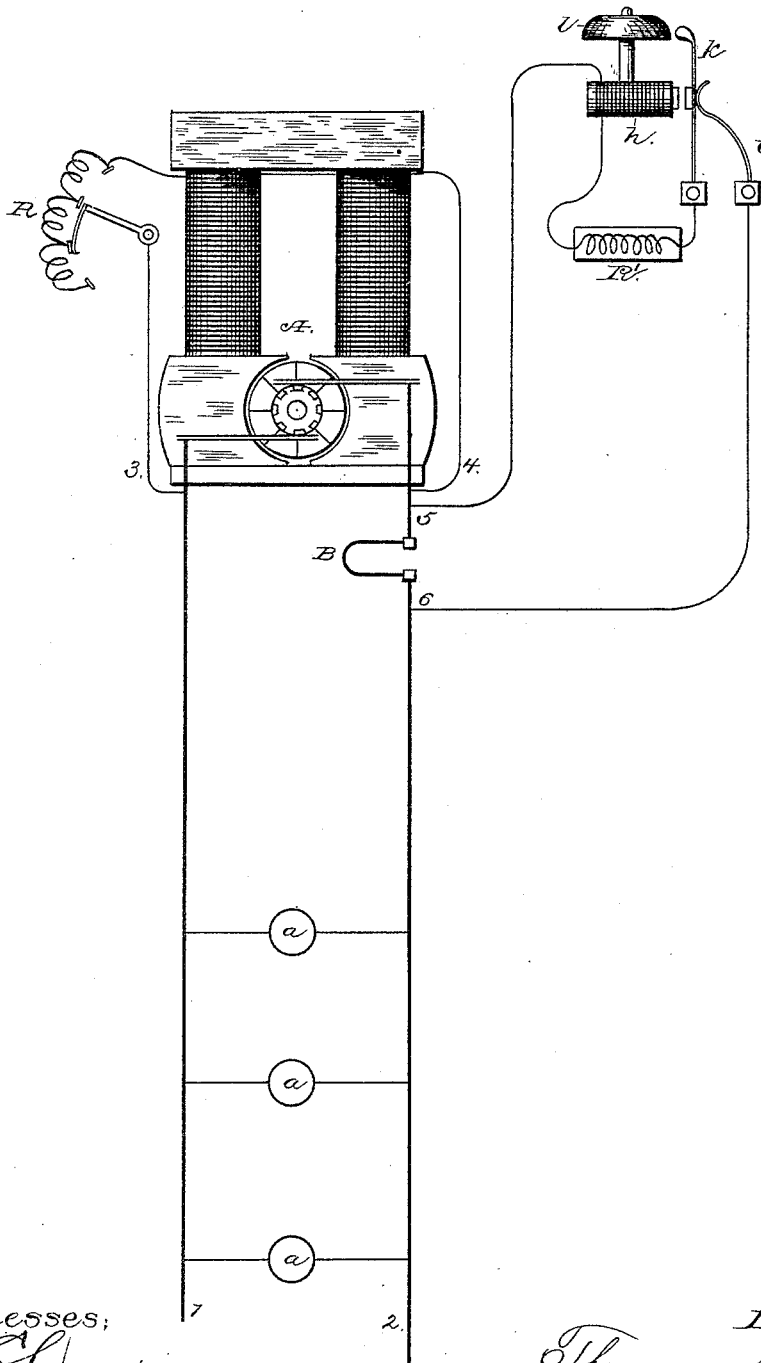

witnesses;
J. C. Clark.
J. C. Schroeder.

Inventor;
Thomas A. Edison.
By *Rich^d. N. Dyer*
Attorney.

UNITED STATES PATENT OFFICE.

THOMAS A. EDISON, OF MENLO PARK, NEW JERSEY, ASSIGNOR TO THE
EDISON ELECTRIC LIGHT COMPANY, OF NEW YORK, N. Y.

ELECTRIC-LIGHTING SYSTEM.

SPECIFICATION forming part of Letters Patent No. 439,392, dated October 28, 1890.

Application filed August 22, 1882. Serial No. 69,995. (No model.) Patented in England March 3, 1882, No. 1,023.

To all whom it may concern:

Be it known that I, THOMAS A. EDISON, of Menlo Park, in the county of Middlesex and State of New Jersey, have invented a new
5 and useful Improvement in Electric-Lighting Systems, (Case No. 473,) of which the following is a specification.

Said invention is patented in Great Britain
10 by Letters Patent No. 1,023, dated March 3, 1882.

The object I have in view is to produce means to be used in connection with dynamo or magneto-electric machines supplying electric lamps or other translating devices ar-
15 ranged in multiple arc, which means will prevent injury to the machine or machines when an abnormally large current is caused to flow by the addition of more lamps or other translating device than the plant has capacity to
20 furnish, and will at the same time notify the engineer of the condition of affairs. This object I accomplish in the following manner: A piece of "safety-catch" wire or material is placed in one of the conductors of the main
25 or consumption circuit. This safety-catch is of such size and character that when more lamps are put in circuit than the plant is designed to furnish, and before the machine or machines are injured by the abnormally-large
30 flow of current, it will burn out and break the circuit between the generator and the translating devices. In a shunt around this safety-catch are arranged a vibrating bell and a resistance, the resistance being sufficient to prevent the striking of the bell when the
35 safety-catch is intact; but when the safety-catch is burned out the current passes through the bell-circuit and operates the bell-hammer. The lights at the same time will drop
40 to a red heat. The engineer then removes a

sufficient number of lamps and replaces the safety-catch. The foregoing will be better understood by reference to the drawing, in which the figure is a diagrammatic view of the parts.

A represents a dynamo or magneto-electric machine; 1 2, the main or consumption circuit, and *a a* incandescing electric lamps or other translating devices located in multiple-arc or derived circuits.

The field-circuit of the machine may be a multiple-arc circuit 3 4 from 1 2, and be provided with an adjustable resistance R.

B is a piece of safety-catch wire or material placed in 1 or 2 between the lamps and
55 the machine A. In a shunt 5 or 6, around B, are arranged a resistance R' and a vibrating bell composed of electro-magnet *h*, spring *v*, bell-hammer *k*, and gong *l*.

What I claim is—

1. The combination of one or more electrical generators and translating devices supplied therefrom, of a safety-catch for preventing injury to said generator or generators when their capacity is exceeded and an
65 alarm adapted to give notice of the destruction of said safety-catch, substantially as set forth.

2. The combination, with the safety-catch between the translating devices and the gen-
70 erator, of an alarm arranged in a shunt-circuit around said safety-catch, substantially as and for the purpose set forth.

This specification signed and witnessed this 12th day of August, 1882.

THOMAS A. EDISON.

Witnesses:

H. W. SEELY,
E. H. PYATT.