

(No Model.)

T. A. EDISON.
DUST PROOF SWIVEL SHAFT BEARING.

No. 474,593.

Patented May 10, 1892.

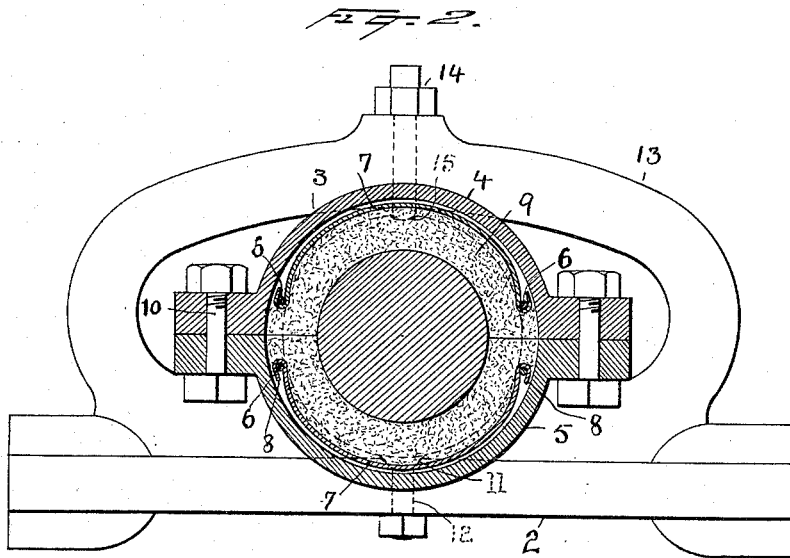
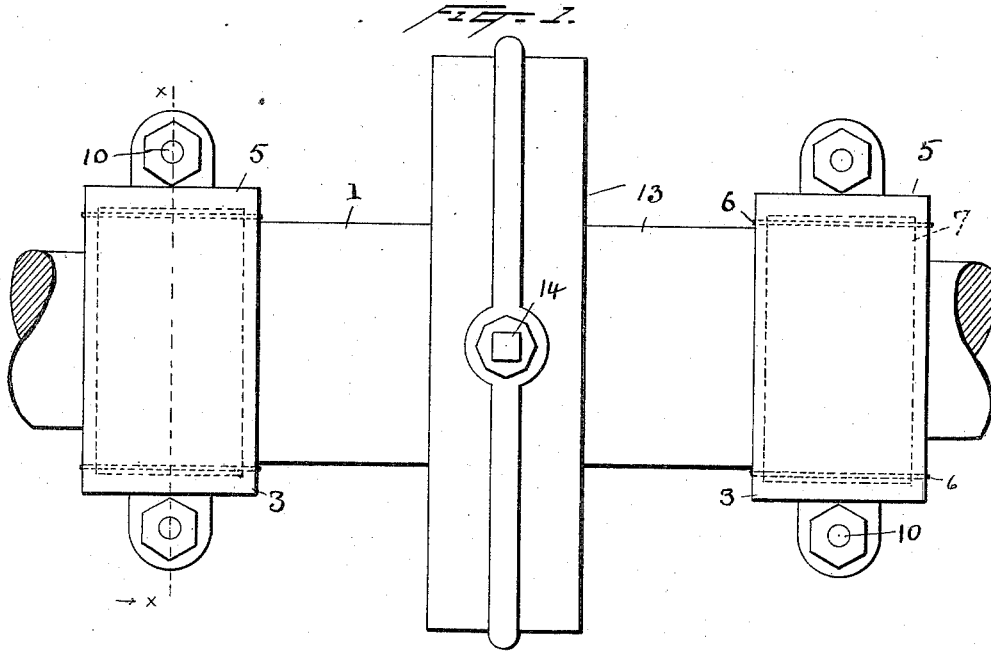

Witnesses
Norris A. Clark.
W. F. Oberly

Inventor
T. A. Edison
By his Attorneys
Lyert Seely

UNITED STATES PATENT OFFICE.

THOMAS A. EDISON, OF LLEWELLYN PARK, NEW JERSEY.

DUST-PROOF SWIVEL SHAFT-BEARING.

SPECIFICATION forming part of Letters Patent No. 474,593, dated May 10, 1892.

Application filed October 8, 1891. Serial No. 408,115. (No model.)

To all whom it may concern:

Be it known that I, THOMAS A. EDISON, a citizen of the United States, residing at Llewellyn Park, in the county of Essex and State of New Jersey, have invented a certain new and useful Improvement in Dust-Proof Shaft-Bearings, (Case No. 938,) of which the following is a specification.

The present improvement relates to means for excluding dust from shaft-bearings, and especially bearings arranged so that they can give slightly when the shaft is subjected to a strain which tends to deflect it out of its true line. The dust-proof joint is particularly useful in connection with ore-milling machinery.

In the accompanying drawings, Figure 1 is a plan view of the bearing; and Fig. 2 is a view on line *x x* of Fig. 1, looking in the direction of the arrow.

The shaft-bearing 1 is supported on any suitable support 2, and the construction of the bearing may be of any suitable character. The bearing-box is preferably cast in two sections, a lower and an upper half. At each end of the bearing-box is an enlargement 3, formed by the parts 4 5, which are preferably, though not necessarily, cast integral with the upper and lower sections of the bearing-box. Extending through the enlargement at two opposite points are rods 6, which serve as supports for the plate-springs 7. These springs are bent back at each end, as indicated at 8, and rest on the rods 6, as shown, one in the upper and one in the lower section. A packing material 9 is placed on top of the spring in the lower section, and the shaft when in place presses said packing material against the spring, bending it away from the shaft and compressing the packing. Packing material is also placed over the shaft, and the upper section 4 is placed on the same, whereby its spring is put under tension. By this simple device the packing is always held

against the shaft on all sides by a yielding spring-pressure sufficient to exclude all dust, but which can yield when the movement of the shaft requires it. The upper and lower sections 4 5 are united by bolts 10. The lower section of the bearing-box is provided with a rounded bulge or boss 11, which rests in a corresponding depression in the foundation or support, and from which extends a bolt 12. Over the bearing is a cast-iron arch 13, provided at its center with a bolt 14, the lower end of which rests in a depression 15 in the top of the bearing-box. The support described makes a swivel support for the bearing, allowing it necessary play, as already indicated.

What I claim is—

1. The combination, in a dust-proof bearing, of a holder at an end of the bearing, supporting-rods in the holder, springs, the ends of which engage and are supported by said rods, and packing material between the springs and shaft, substantially as described.

2. The combination, in a dust-proof bearing, of a sectional holder at an end of the bearing, supporting-rods in each section, springs, the ends of which are supported by said rods, and packing material between the springs and shaft, substantially as described.

3. The combination, in a dust-proof bearing, of a holder forming a part of the bearing-box, supporting-rods therein, springs having hooks or sockets at their ends engaging said rods, and packing material between the springs, and a shaft supported in the bearing, substantially as described.

This specification signed and witnessed this 28th day of August, 1891.

THOS. A. EDISON.

Witnesses:

CHARLES M. CATLIN,
JOHN F. RANDOLPH.