

(No Model.)

T. A. EDISON.  
PHONOGRAPH REPRODUCER.

No. 484,584.

Patented Oct. 18, 1892.

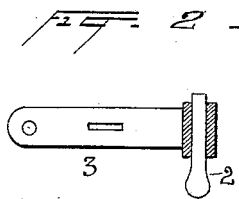
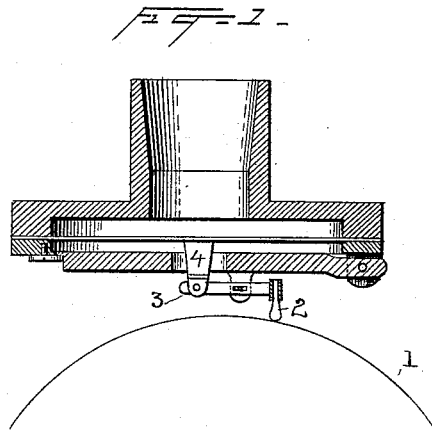

Witnesses  
Morris A. Clark  
Charles M. Catlin.

Inventor  
T. A. Edison.  
By his Attorneys  
Lyert Seely.

# UNITED STATES PATENT OFFICE.

THOMAS A. EDISON, OF LLEWELLYN PARK, NEW JERSEY.

## PHONOGRAPH-REPRODUCER.

SPECIFICATION forming part of Letters Patent No. 484,584, dated October 18, 1892.

Application filed May 27, 1890. Renewed March 30, 1892. Serial No. 427,013. (No model.)

*To all whom it may concern:*

Be it known that I, THOMAS A. EDISON, a citizen of the United States, residing at Llewellyn Park, in the county of Essex and State of New Jersey, have invented a certain new and useful Improvement in Phonograph-Reproducers, (Case No. 862,) of which the following is a specification.

In practice it is found that after phonographs have been used for a time the articulation of the speech reproduced is not so smooth and clear as when the phonograph was first put in use. While the articulation is sufficiently good to be intelligible, the false vibrations are such as to cause unpleasant and some times confusing noises at the reproducer. I attribute this to the fact that by continued use the cutting-edge of the recorder and of the turning-off tool and the bearing point or end of the reproducer become roughened. The recording-surface of the phonogram-blank is ordinarily of wax or a stearate or hard metallic soap or other wax-like material or composition, and it would naturally be supposed that a tool of steel of the best quality would be entirely satisfactory for use in connection with such a comparatively-soft substance. I have, however, found that such tools are subject to the objection above set forth. This is due to the chemical action of acids or other substances found in the wax or composition of which the phonogram-blank is made, and to the dulling and roughening action of fine particles of silica or other hard material which become mixed with the wax during the manufacture of the blank or which become lodged on the surface thereof. After many trials I have found that hard crystals, earthy oxides, and gems—such, for example, as sapphire, quartz, or garnet, all of which may be termed “jewels”—co-operate in the most effective manner with the wax-like phonogram-blank, since the acids thereof do not attack them, they are not rusted by moisture, and they are adapted to withstand the dulling action of the hard particles referred to.

The present invention consists, in a reproducer for phonographs, of a jewel possessing the characteristics above mentioned.

The recorder and turning-off tool are not claimed herein, since they form the subject-matter of an application filed by me on even date herewith.

In the accompanying drawings, which illustrate the invention, Figure 1 is a view of the reproducer bearing on the surface of a phonogram-blank. Fig. 2 is a detached view, on a larger scale, of the reproducer.

1 is the surface of the phonogram-blank.

2 is the jewel reproducing-point, the bearing end of which is preferably spherical or rounded. This jewel is held in any suitable manner at one end of the pivoted lever 3, the opposite end of which is connected to the phonograph-diaphragm by means of the post 4. Reproducing-points made as above described not only are more durable than those of metal, but they move more readily over the record and do not introduce false vibrations into sounds reproduced.

Having thus described my invention, what I claim is—

1. The combination, in a phonograph, with a phonogram-blank of wax-like material, of a jewel reproducer, substantially as described.

2. The combination, in a phonograph, with the phonogram-blank, of a rounded jewel reproducer, substantially as described.

3. A reproducer or bearing-point for phonographs, consisting of a jewel not affected by chemicals or chemical action of the wax-like material of the phonogram-blank, substantially as described.

This specification signed and witnessed this 24th day of May, 1890.

THOS. A. EDISON.

Witnesses:

A. O. TATE,  
THOMAS MAGUIRE.