

No. 622,843.

T. A. EDISON.
PHONOGRAPH.

Patented Apr. 11, 1899.

(No Model.)

(Application filed Dec. 8, 1890.)

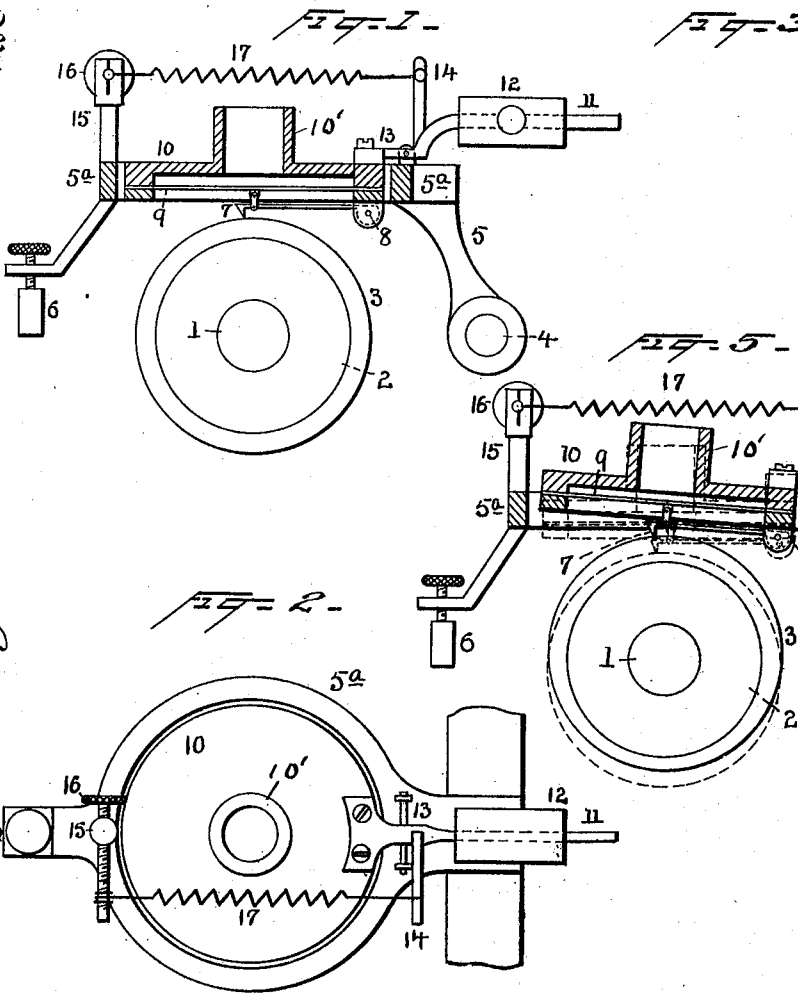
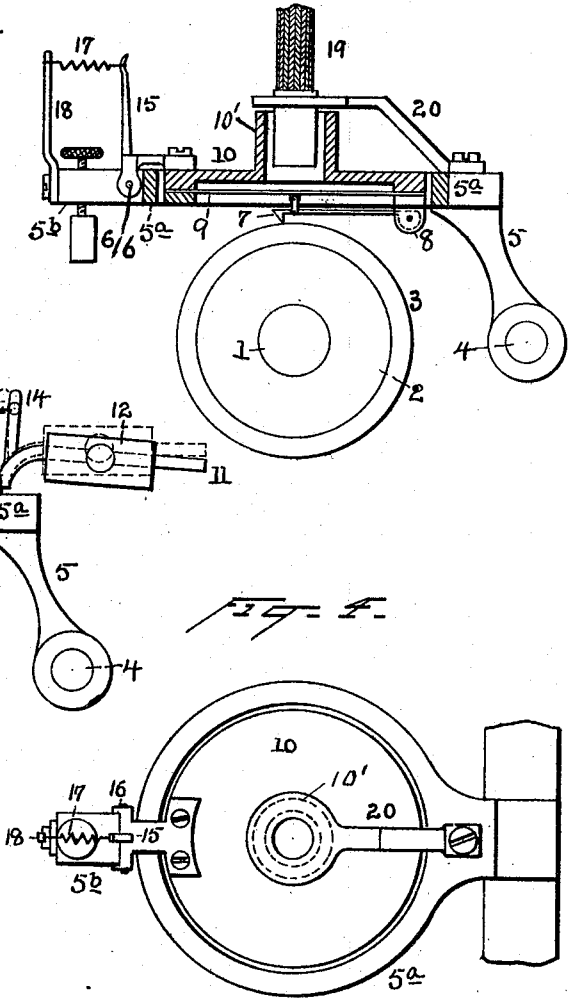

Witnesses
Thomas A. Clark
[Signature]

Thomas A. Edison
Inventor
By *[Signature]* Attorney
[Signature]

UNITED STATES PATENT OFFICE.

THOMAS A. EDISON, OF LLEWELLYN PARK, NEW JERSEY.

PHONOGRAPH.

SPECIFICATION forming part of Letters Patent No. 622,843, dated April 11, 1899.

Application filed December 3, 1890. Serial No. 373,407. (No model.)

To all whom it may concern:

Be it known that I, THOMAS A. EDISON, a citizen of the United States, residing at Llewellyn Park, in the county of Essex and State of New Jersey, have invented a certain new and useful Improvement in Phonographs, (Case No. 889,) of which the following is a specification.

My invention relates to phonograph-recorders and reproducers; and it consists in means for enabling the recorder or reproducer to operate satisfactorily notwithstanding irregularities or eccentricities which are sometimes found in the surface of the phonogram-blanks owing to imperfections in their manufacture or to warping after manufacture.

The invention is based upon the disclosures of my caveat No. 111, (Official No. 147/10,308,) filed October 26, 1888.

In the accompanying drawings, Figure 1 is a sectional view and partial elevation of a phonograph embodying my invention. Fig. 2 is a top view of the same. Fig. 3 is a view similar to Fig. 1 of a modified form. Fig. 4 is a top view of the form shown in Fig. 3. Fig. 5 is a view similar to Fig. 1, illustrating in exaggerated form the bodily movements of the recorder or reproducer to compensate for eccentricities of the phonogram-blank.

Referring to Figs. 1, 2, and 5, 1 is the phonograph-shaft, 2 the phonograph-cylinder, and 3 the phonogram-blank.

4 is the guide-rod upon which the recorder or reproducer carrying arm 5 is mounted, so that such arm can be swung upon said rod to lift the recorder or reproducer off of the blank and so that said arm can be moved longitudinally on said rod by the feeding mechanism of the phonograph, as will be well understood. The carrying-arm 5 projects forward over the phonograph-cylinder and at its forward free end rests upon the guide-bar 6, upon which it slides in the operation of the phonograph. Its bearing on the guide-bar 6 may be made adjustable by means of a thumb-screw. Over the phonograph-cylinder the carrying-arm 5 is opened out into the form of a ring 5^a, in which the recorder or reproducer is pivoted, so that the recording or reproducing point will rest directly by the weight of the entire recorder or reproducer (counterbalanced so far as may be necessary) upon

the blank or record. The recorder or reproducer consequently has a floating action and rises and falls bodily to compensate for eccentricities of the blank, as illustrated in exaggerated form in Fig. 5, while the inertia of the recorder or reproducer is such that with respect to the minute elevations and depressions which constitute the sound-record its position is always fixed and the movements produced by the sound-waves in recording or by the sound-record in reproducing are communicated to the diaphragm and point without producing any bodily movement of the recorder or reproducer.

7 is the recording or reproducing point, shown as pivoted at 8 to the diaphragm-ring 10 and operatively connected with the diaphragm 9. Said diaphragm is mounted in the ring or frame 10 in the ordinary manner. The diaphragm-ring 10 is secured to the lever 11, which is pivoted at 13 to the carrying-arm. The lever 11 has an adjustable weight 12 upon it, which may be adjusted to balance more or less completely or actually overbalance the weight of the recorder or reproducer. To secure a finer adjustment, a spring 17 may be provided, extending from an arm 14 on the lever 11 to a post 15 on the ring 5^a of the carrying-arm 5. The spring 17 is capable of being adjusted by a thumb-screw 16, and the tension of that spring tends to throw the recorder or reproducer toward the surface of the blank or record.

In the modification shown in Figs. 3 and 4 the diaphragm-ring is secured to a lever 15, which is pivoted on the forward end or finger-piece 5^b of the carrying-arm. From this finger-piece rises the standard 18, to which the lever 15 is connected by means of the balancing-spring 17. In this instance the spring tends to lift the recorder or reproducer off of the surface of the blank or record, while the weight of the recorder or reproducer, which is not completely counterbalanced by the spring, causes the recording or reproducing point to engage with the blank or record. A speaking or listening tube 19 is supported by an arm or standard 20, which is mounted on the carrying-arm 5. The end of the tube 19, which enters the neck of the diaphragm-ring 10, is smaller in diameter than the opening in the neck. The speaking or listening tube 19 is

thus supported independently of the recorder or reproducer, so that the recorder or reproducer is not retarded in its movement by the weight of the tube. The tube 19 and its support are shown only in connection with Figs. 3 and 4; but it will be understood that the tube will be supported in the same manner for the form of recorder or reproducers shown in Figs. 1, 2, and 5.

10 What I claim is—

1. In a phonograph, the combination with the phonograph-cylinder, of a carrying-arm pivoted on a guide-rod in rear of the cylinder and projecting over the cylinder to a guide-rest in front thereof, and a recorder or reproducer pivotally supported by the carrying-arm and having the recording or reproducing point resting directly upon the blank or record, whereby the recorder or reproducer is moved bodily by eccentricities in the blank or record surface, substantially as set forth.

2. In a phonograph, the combination with the phonograph-cylinder, of a carrying-arm pivoted on a guide-rod in rear of the cylinder and projecting over the cylinder to a guide-rest in front thereof, a recorder or reproducer pivotally supported by the carrying-arm and having the recording or reproducing point

resting directly upon the blank or record, whereby the recorder or reproducer is moved bodily by eccentricities in the blank or record surface, and balancing devices for counterbalancing the excessive weight of the recorder or reproducer, substantially as set forth.

3. In a phonograph, the combination with the phonograph-cylinder, of a carrying-arm pivotally supported on a guide-rod in rear of the cylinder and projecting over the cylinder and resting on a guide-rest at its forward free end, a recorder or reproducer pivotally supported by the carrying-arm and having the recording or reproducing point resting directly upon the blank or record, such recorder or reproducer moving bodily to compensate for eccentricities of the blank or record surface, and a speaking or listening tube supported independently of the recorder or reproducer so as not to interfere with its bodily movements, substantially as set forth.

This specification signed and witnessed this 1st day of December, 1890.

THOS. A. EDISON.

Witnesses:

JOHN F. RANDOLPH,
W. PELZER.