

No. 685,911.

Patented Nov. 5, 1901.

T. A. EDISON.

APPARATUS FOR REHEATING COMPRESSED AIR FOR INDUSTRIAL PURPOSES.

(Application filed Dec. 6, 1899.)

(No Model.)

4 Sheets—Sheet 1.

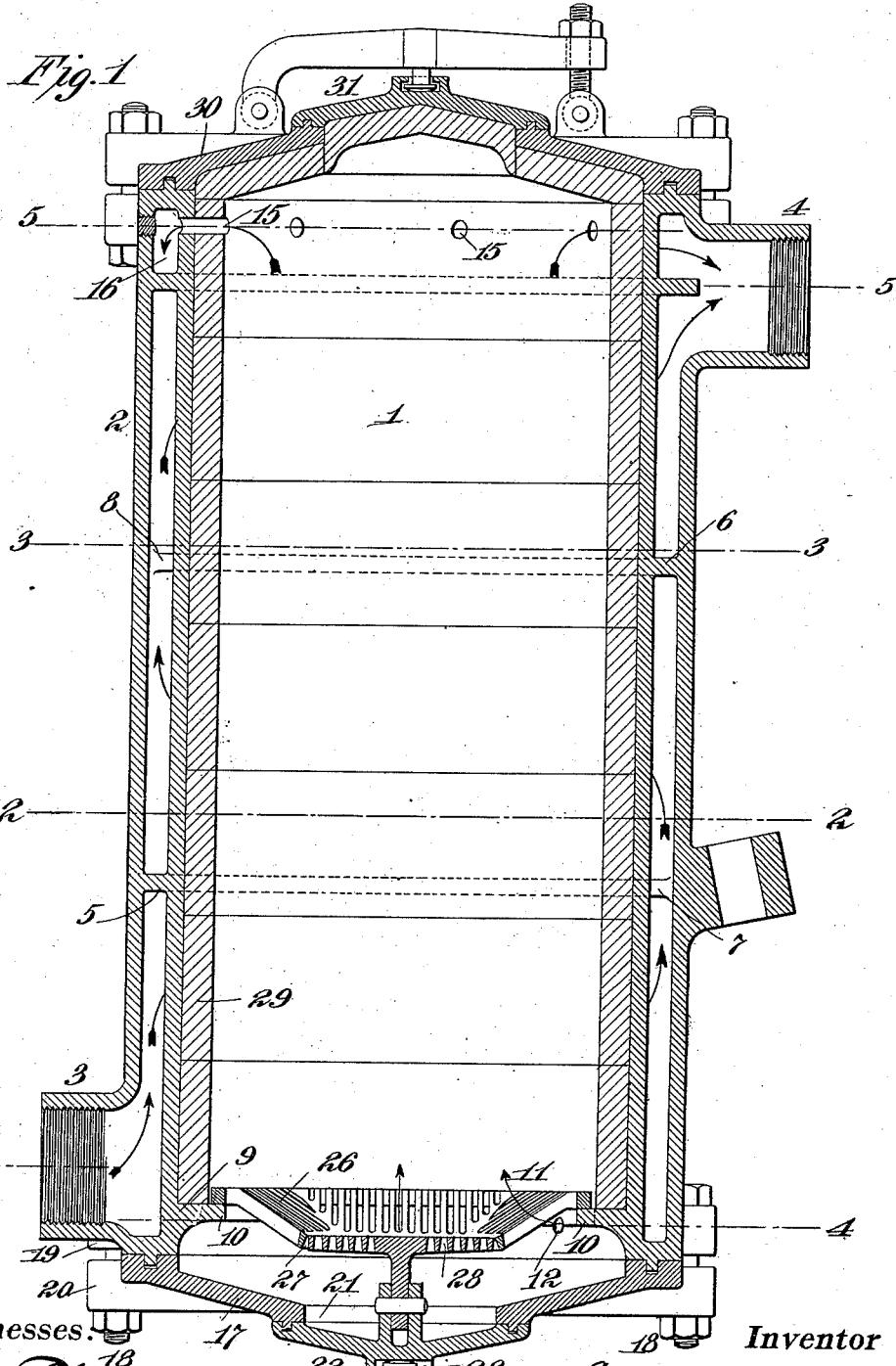

Witnesses.

Justus W. DeMan
John R. Taylor

Inventor

Thomas A. Edison

By *Edmund S. Allen*
 Att'ys.

No. 685,911.

Patented Nov. 5, 1901.

T. A. EDISON.

APPARATUS FOR REHEATING COMPRESSED AIR FOR INDUSTRIAL PURPOSES.

(Application filed Dec. 6, 1899.)

(No Model.)

4 Sheets—Sheet 2.

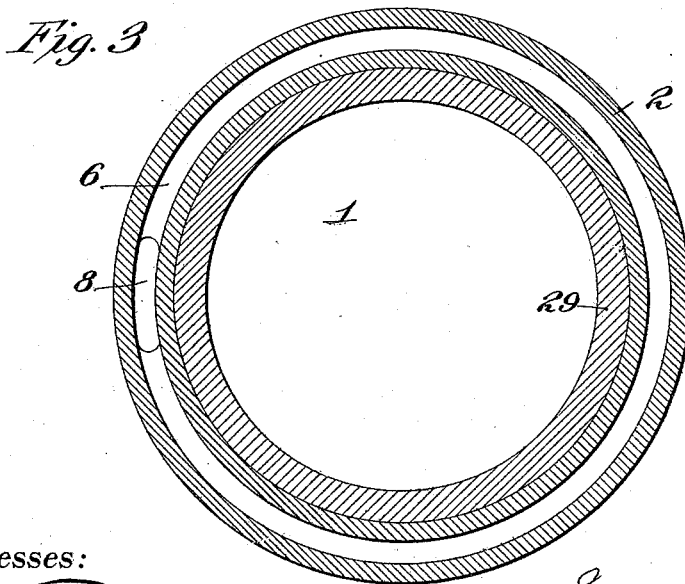
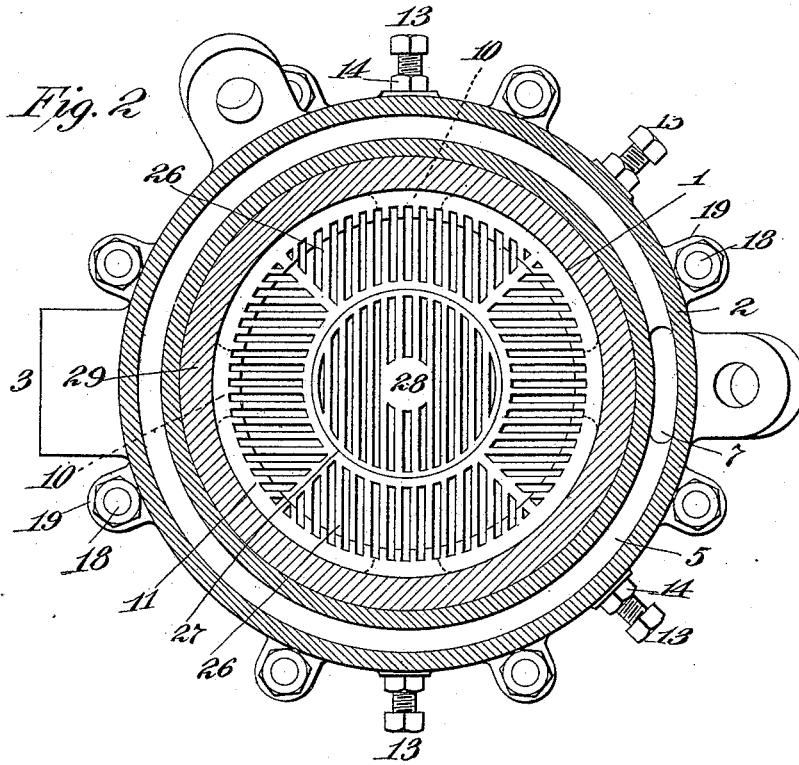

Witnesses:

John R. Brown
John A. Taylor

Inventor

Thomas A. Edison
by *Spencer Edmund Alden*

Att'ys.

T. A. EDISON.

APPARATUS FOR REHEATING COMPRESSED AIR FOR INDUSTRIAL PURPOSES.

(Application filed Dec. 6, 1899.)

(No Model.)

4 Sheets—Sheet 3.

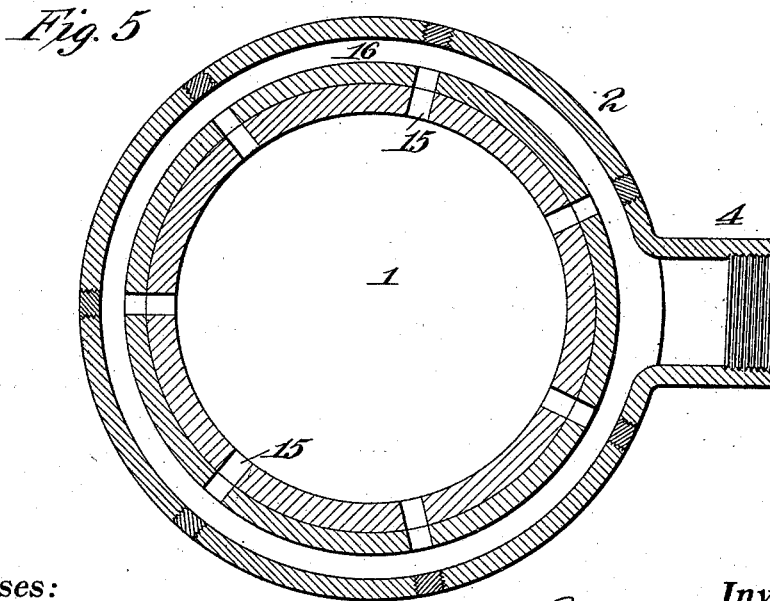
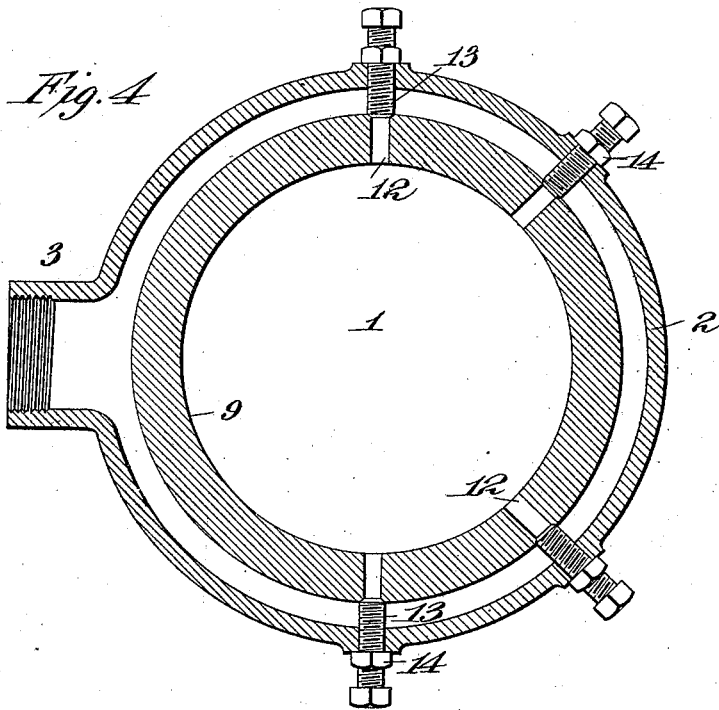

Witnesses:

Jas. Tolman
Geo. R. Taylor

Inventor

Thomas A. Edison

Edw. Edmunds

Att'ys

No. 685,911.

Patented Nov. 5, 1901.

T. A. EDISON.

APPARATUS FOR REHEATING COMPRESSED AIR FOR INDUSTRIAL PURPOSES.

(Application filed Dec. 6, 1899.)

(No Model.)

4 Sheets—Sheet 4.

Fig. 6

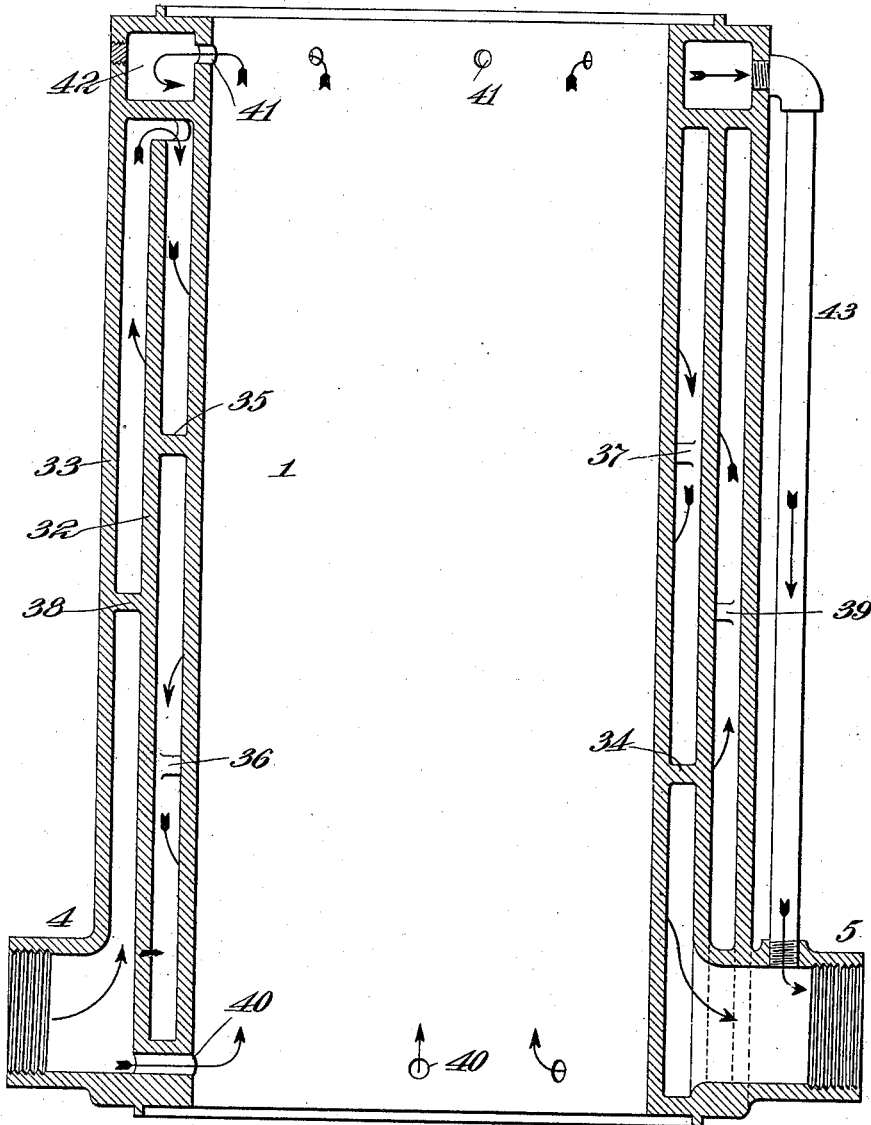

Witnesses:

*Jas. F. Holman
 Jno. R. Taylor*

Inventor

*Thomas A. Edison
 by Hyer Edmunds & Co.
 Att'ys*

UNITED STATES PATENT OFFICE.

THOMAS A. EDISON, OF LLEWELLYN PARK, NEW JERSEY.

APPARATUS FOR REHEATING COMPRESSED AIR FOR INDUSTRIAL PURPOSES.

SPECIFICATION forming part of Letters Patent No. 685,911, dated November 5, 1901.

Application filed December 6, 1899. Serial No. 739,342. (No model.)

To all whom it may concern:

Be it known that I, THOMAS A. EDISON, a citizen of the United States, residing at Llewellyn Park, in the county of Essex and State of New Jersey, have invented a certain new and useful Apparatus for Reheating Compressed Air for Industrial Purposes, (Case No. 1,018,) of which the following is a specification.

In my patent numbered 643,764, dated February 20, 1900, (Case No. 1,005,) I describe and claim an improved process or method of reheating compressed air for industrial purposes consisting in directing a portion of the compressed air into intimate proximity with a source of burning combustible, whereby heat will be imparted to the compressed air by radiation; in effecting a reduction in pressure of the air between the source of heat and the point of use; in causing a portion of the air to flow by reason of such reduction of pressure through the burning combustible, whereby combustion will be maintained and the air so introduced will be directly heated to a very high temperature, and in mixing the directly-heated portion of the air with the indirectly-heated portion of the air prior to use.

My present invention contemplates an improved apparatus for the carrying out of this method; and the object of the invention is to provide a simple and effective apparatus for the purpose.

In carrying out my invention I provide a reheating-chamber, in which the combustion is effected, and surround said chamber with a jacket through which the indirectly-heated portion of air will pass, said jacket being divided into a plurality of sections, whereby the indirectly-heated air will be caused to partake of a tortuous course and will be longer subjected to the effect of the heat. I also prefer to dispense with the employment of exterior piping for conducting the air through the burning combustible, as I describe in my said patent, by leading the air directly into the reheating-chamber from said jacket and by leading the air which has been directly heated out of said chamber into the jacket. This makes the device simpler, and less opportunity is afforded for loss by radiation.

The present invention also contemplates

detailed improvements in the construction of the apparatus for facilitating the charging of the device with fresh quantities of fuel and for the removal of accumulated ash.

In order that the invention may be better understood, attention is directed to the accompanying drawings, forming part of this specification, and in which—

Figure 1 is a longitudinal sectional view of the preferred construction of apparatus; Fig. 2, a horizontal section on the line 2 2 of Fig. 1; Fig. 3, a similar view on the line 3 3 of Fig. 1; Fig. 4, a section on the line 4 4 of Fig. 1; Fig. 5, a section on the line 5 5 of Fig. 1; and Fig. 6 a longitudinal sectional view of a modification in the construction of the reheating-chamber and jackets, showing the employment of two sectional jackets instead of one sectional jacket, the end heads, grate, controlling-valves, and lining being omitted for the purpose of clearness.

In all of the above views the normal flow of the air-currents is indicated by arrows, and in all of such views corresponding parts are represented by the same numerals of reference.

Referring first to Figs. 1 to 5, inclusive, 1 is a cylindrical reheating-chamber, having an inclosing jacket 2, which may be conveniently cast integral with the chamber 1. The jacket is provided with two nipples 3 and 4, with which the air-conducting pipe is engaged, air being admitted through the nipple 3 and taken out through the nipple 4. The space inclosed by the jacket 2 is divided into any number of main sections, three of such sections being shown. This sectional division of the space inclosed by the jackets is effected by means of partitions or diaphragms 5 and 6, the former being provided with an opening 7 therein and the latter with an opening 8, diametrically disposed with respect to the former opening. Air being admitted into the space inclosed by the jacket through the nipple 3 will flow around the lower part of the reheating-chamber 1, up through the opening 7 in the partition 5, again around the main portion of the reheater 1, up through the opening 8 in the partition 6, and again around the upper portion of the reheater 1, out through the nipple 4, thus partaking of a tortuous course, so as to be more effectively heated than

if the air were allowed to pass directly from the nipple 3 around the reheating-chamber 1 and out through the nipple 4. The reheating-chamber 1 is provided near its bottom with an annular shoulder 9, having a plurality of lugs 10, on which is carried the main portion 11 of the grate. A plurality of openings 12 extend through the wall of the reheating-chamber 1 at about the line of the shoulder 9 and communicate with the space inclosed by the jacket 2, as shown, whereby a portion of the air entering within said jacket may be permitted to pass into the reheating-chamber below the grate, so as to be directly heated, as will be explained. Any number of openings 12 may be employed, four being shown. Each opening is controlled by a valve 13, formed of an ordinary bolt passing through the jacket 2 and having a lock-nut 14. By adjusting these valves the proper quantity of air will be allowed to enter the interior of the reheating-chamber. The provision of the partitions 5 and 6 with the openings 7 and 8 therein produces a choking effect on the air passing around the reheating-chamber and causes air to flow through the openings 12 into the reheating-chamber by reason of the drop in pressure thus secured, as I describe in my said patent. Air is taken out of the reheating-chamber at its upper end through the openings 15, which lead into an annular passage 16, opening directly into the space inclosed by the nipple 4. A bottom 17 is removably secured in place by bolts 18, engaging with lugs 19 and 20 on the reheater and said bottom, respectively, whereby said bottom may be removed when desired. The bottom 17 is formed with an opening 21 therein, adapted to be closed by a cover 22. The cover 22 is formed with a grooved socket 23, with which engages the head of a bolt 24, said bolt being carried by a bridge 25, hinged at one side in lugs carried by the bottom 17 and supported at the other side by a clamping-bolt, as shown. The main grate 11, before referred to, is provided with the inclined grate-bars 26, leading to an opening 27 therein, said opening being adapted to be normally closed by an auxiliary grate 28, carried in lugs by the cover 22. It will be seen that by unclamping the bridge 25 the cover 22 may be swung downward, carrying the auxiliary grate with it. By inclining the grate-bars 26 any ash deposited on the main grate will fall out through the opening 27 therein and through the opening 21 in the bottom 17. In this way it becomes unnecessary to swing open the entire bottom when it is desired to remove ash. The interior of the reheating-chamber 1 is preferably lined with fire-brick 29, as shown, and the upper end of the reheating-chamber is closed by means of a top 30, having a cover 31, corresponding to the bottom and cover referred to. By swinging upward the cover 31 fresh quantities of material may be introduced into the reheating-chamber and combustion started.

The operation of the device will be readily understood. The pipes for carrying the compressed air are connected to the nipples 3 and 4, so that the device will be interposed in the pipe-line. A sufficient quantity of a preferably solid combustible material being introduced into the reheating-chamber and being carried upon the grates 11 and 28, combustion is started in any suitable way, as by introducing within the reheating-chamber a handful of lighted waste saturated in oil. The top and bottom being closed the air will pass through the sectional jacket in the path indicated by the arrows, and a much smaller portion of the air will be deflected through the openings 12 into the reheating-chamber, passing upward through the burning combustible, so as to support combustion thereof and be heated directly, and passing out of the reheating-chamber through the openings 15, being reunited within the nipple 4 with the directly-heated portion of air which has passed through the jacket.

Instead of providing the reheating-chamber with a single jacket, as explained, it may be provided with two or more jackets, as shown in Fig. 6. In this figure the reheating-chamber 1 is provided with two concentric inclosing jackets 32 and 33, the space inclosed by the former being divided into three sections by means of two partitions 34 and 35, having the openings 36 and 37 therein. The space inclosed by the outer jacket 33 is divided into two sections by means of a single partition 38, having an opening 39 therein. In this case the nipple 4, leading the compressed air to the device, connects with the lower section of the space inclosed by the outer jacket, while the nipple 5, leading the air out of the reheater, connects with the bottom section of the space inclosed by the inner jacket. Air is admitted directly into the reheating-chamber by means of openings 40, leading from the space inclosed by the outer jacket, as shown, and which may be provided with regulating-valves, as explained. The directly-heated air is taken out of the reheater through openings 41 into a space 42, which connects, by means of a pipe 43, with the nipple 5. With this modification it will be observed that the air which is to be indirectly heated will enter by the nipple 4, passing around the inner jacket 32, up through the opening 39, again around the inner jacket into the upper section inclosed by the inner jacket, thence through the opening 37, around the reheating-chamber, down through the opening 36 into the lower section inclosed by the inner jacket 32, around the reheating-chamber 1, and out through the nipple 5. The air which is to be directly heated will pass through the openings 40 into the reheating-chamber, out through the openings 41 into the chamber 42, and by means of the pipe 43 into the nipple 5, where the directly-heated air will be reunited with the indirectly-heated air.

Having now described my invention, what I claim as new, and desire to secure by Letters Patent, is as follows:

1. In a reheater for compressed air, the combination of a reheating-chamber, a jacket surrounding the same, a grate in said chamber for carrying a combustible material, air-pipes leading directly to and directly from the jacket, an opening connecting the space inclosed by the jacket with the interior of said reheater below the grate, whereby a portion only of the air will be admitted into the interior of the reheater to support combustion of the combustible material, and means for conducting the directly-heated air to the discharge-pipe which leads directly from said jacket, substantially as set forth.

2. In a reheater for compressed air, the combination of a reheating-chamber, a jacket surrounding the same, a grate in said chamber for carrying a combustible material, air-pipes leading directly to and directly from the jacket, an opening connecting the space inclosed by the jacket with the interior of said reheater below the grate, whereby a portion only of the air will be admitted into the interior of the reheater to support combustion of the combustible material, means for conducting the directly-heated air to the discharge-pipe which leads directly from said jacket, and a valve for said opening, substantially as set forth.

3. In a reheater for compressed air, the combination of a reheating-chamber, a jacket surrounding the same, an inlet-pipe leading into the space inclosed by said jacket near the bottom thereof, a discharge-pipe leading directly out of the space inclosed by said jacket near the top thereof, a grate in the reheater for carrying a combustible material, an opening connecting the space below said grate with the space inclosed by said jacket, and an opening connecting the interior of the upper portion of the reheating-chamber with said jacket adjacent to the discharge-pipe, substantially as set forth.

4. In a reheater for compressed air, the combination of a reheating-chamber, a jacket surrounding said chamber, an inlet-pipe leading into said jacket near the bottom thereof, an exit-pipe leading directly out of said jacket near the top thereof, a plurality of partitions for subdividing the space inclosed by said jacket, said partitions having openings therein through which the air passes, a

grate in said reheating-chamber, openings connecting the lower section of the space inclosed by the jacket with the interior of said reheating-chamber below the grate, and openings connecting the upper space inclosed by such jacket with the interior of the reheating-chamber, substantially as set forth.

5. In a reheater for compressed air, the combination of a reheating-chamber, a main grate within the reheating-chamber on which the combustible material is placed, a cover for the reheating-chamber at its lower end, and a supplemental or auxiliary grate carried by said cover and cooperating with the main grate, substantially as set forth.

6. In a reheater for compressed air, the combination of a reheating-chamber, a main grate carried within the reheating-chamber, said grate having an opening therein, a supplemental grate fitting in said opening, and a cover for the bottom of said reheating-chamber carrying said supplemental grate, substantially as set forth.

7. In a reheater for compressed air, the combination of a reheating-chamber, a bottom for said chamber having an opening therein, a cover for closing said opening, a grate within the chamber having an opening therein, and an auxiliary grate fitting said opening and carried by said cover, substantially as set forth.

8. In a reheater for compressed air, the combination of a reheating-chamber, a jacket surrounding the chamber substantially for its entire length, an air-supply pipe leading into the jacket near the lower end thereof, a partition within the jacket dividing it into a plurality of sections and having an opening oppositely disposed with respect to the inlet-pipe, an exit-pipe leading directly from the jacket, a grate within the chamber, openings leading from the space inclosed by the jacket to the interior of the heating-chamber below the grate, and openings leading out of the heating-chamber near its upper end into the space inclosed by the jacket and adjacent to the exit-pipe therefrom, substantially as set forth.

This specification signed and witnessed this 24th day of November, 1899.

THOMAS A. EDISON.

Witnesses:

J. F. RANDOLPH,
W. E. GILMORE.