

T. A. EDISON.  
PHONOGRAPHIC RECORDING APPARATUS.

(Application filed Mar. 17, 1899.)

(No Model.)

Fig. 1

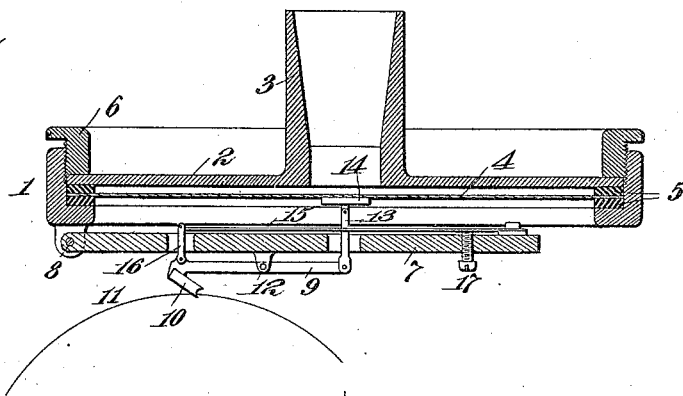

Fig. 2

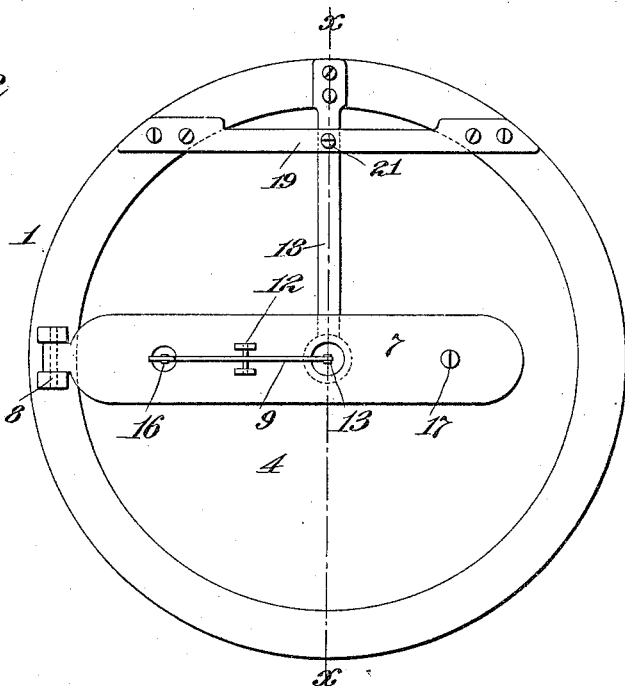
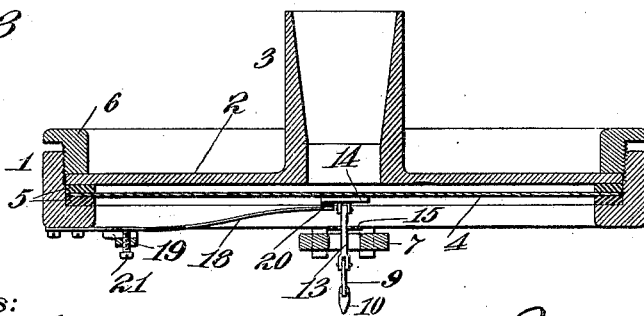

Fig. 3



Witnesses:

*Joost. Glenn*  
*Geo. R. Taylor*

Inventor

*Thomas A. Edison*  
*By Wm. Edwards & Son*  
Attys.

# UNITED STATES PATENT OFFICE.

THOMAS A. EDISON, OF LLEWELLYN PARK, NEW JERSEY.

## PHONOGRAPHIC RECORDING APPARATUS.

SPECIFICATION forming part of Letters Patent No. 688,610, dated December 10, 1901.

Application filed March 17, 1899. Serial No. 709,448. (No model.)

*To all whom it may concern:*

Be it known that I, THOMAS A. EDISON, a citizen of the United States, residing at Llewellyn Park, in the county of Essex and State of New Jersey, have invented a certain new and useful Improvement in Phonographic Recording Apparatus, (No. 1,003,) of which the following is a specification.

My invention relates to various improvements in apparatus for making phonographic records; and the object of the invention is to improve the sensitiveness and accuracy of the recording mechanism.

The invention consists in so arranging the diaphragm or other element influenced or vibrated by the sound-waves as to normally relieve it of all or substantially all stress, whereby it will be maintained in substantial equilibrium and will be more sensitively receptive and more accurately responsive to sound-vibrations.

In phonographic recorders as heretofore constructed the diaphragms or equivalent devices have either been placed under a strain by the compensating weight employed to cause the cutting or engraving tool to properly track upon the recording-surface and at the same time to accommodate any eccentricities or variations in the blank or in cases where no weight is employed for this purpose the pressure necessary to properly engage the cutting or engraving tool with the recording material to the requisite depth to record the movements of the diaphragm under the sound-vibrations of itself places the diaphragm under stress. These strains destroy to a great extent the sensitiveness of the diaphragm or other vibrating element, especially to the weak overtones of musical instruments, and prevent the accurate recording thereof.

In order to overcome the objection indicated, the invention consists in employing a counteracting-spring coöperating with the diaphragm and which counteracts the normal strains to which the diaphragm may be subjected, either due to the employment of the usual compensating weight or to the direct engagement of the recording device with the record, as with some types of phonograph-recorders.

In the accompanying drawings, Figure 1 is

a sectional view through a phonograph-recorder of the type employing a compensating weight, illustrating my present improvements applied thereto, including the employment of a secondary or auxiliary spring; Fig. 2, a bottom view of the same; Fig. 3, a section on the line X X of Fig. 2.

In all of the above views corresponding parts are represented by the same numerals of reference.

1 is the usual cylindrical casing, having a top 2, provided with a nipple 3, to which the speaking-tube is secured.

4 is the diaphragm, held in place between the rubber buffers 5 5, and 6 the clamping-ring for forcing the top 2 upon the upper buffer.

7 represents the compensating weight, pivoted at 8, and 9 the recording-lever, carrying the cutting or engraving tool 10 at one end, which engages with the recording-surface 11, generally in the form of a cylinder. The lever 9 is pivoted at 12 to the compensating weight 7 and connects at its free end by a link 13 with a small disk 14, secured to the center of the diaphragm 4 in any suitable way, as by means of shellac. Preferably I employ an auxiliary spring 15, connected to one end of the weight 7, as shown, and at the other end by a link 16 to the working end of the lever 9. This spring tends to depress the cutting or engraving tool 10 with an additional tension into engagement with the recording-surface and prevents successive vibrations of the cutting or engraving tool from the effects of momentum or the actual "jumping" thereof when subjected to the effect of unusually powerful vibrations. An adjusting-screw 17 is employed for adjusting the tension of the spring 15 when used.

Heretofore the tendency of the compensating weight 7 has been to exert a downward stress upon the diaphragm 4, and by reason of this stress the diaphragm is not affected sensitively by the vibrations, nor does it respond accurately thereto. I therefore provide for the elimination of any stress upon the diaphragm, whereby it will be maintained in substantial equilibrium, for the reasons which I have explained. With a device of this character either a counteracting spring or weight may be employed, the former being prefer-

able with the specific form of recorder shown. This counteracting-spring 18 is secured to the bottom of the casing 1, passes above a bridge 19, and at its free end bears beneath the disk 14, a section of rubber 20 or other elastic material being interposed between the spring and said disk to prevent any rubbing sounds from being recorded. An adjusting-screw 21 engages through the bridge 19 and bears against the counteracting-spring 18, whereby the exact stress or strain which is exerted upon the diaphragm 4 by the compensating weight 7 and the auxiliary spring 15, if used, may be removed from the diaphragm and taken up by the spring 18. In this way the diaphragm will be maintained in absolute equilibrium, normally as much so, in fact, as if there were no connection whatever between it and the recording mechanism. Therefore it is in a condition to respond sensitively to vibrations of every character and to accurately record them. At the same time the connecting mechanism between the diaphragm and the cutting or engraving tool will be under stress, whereby the cutting or engraving tool will respond to all vibrations, however abrupt, without lost motion or false motions due to momentum.

Having now described my invention, what I claim as new, and desire to secure by Letters Patent, is as follows:

1. In a phonographic recording device, the combination with a diaphragm, of a recording device connected therewith, a counteracting-spring for counteracting the stress imposed upon the diaphragm by the engagement of the recording device with the recording-surface, and an elastic cushion between the counteracting-spring and the diaphragm, substantially as set forth.

2. In a phonographic recording device, the combination with a diaphragm, of a compensating weight, a recorder connected with the diaphragm and said compensating weight, and means for counteracting the stress imposed upon the diaphragm by the compensating weight, substantially as set forth.

3. In a phonographic recording device, the combination with a diaphragm, of a compensating weight, a recorder connected with the diaphragm and said compensating weight, and a spring connected with the diaphragm for counteracting the stress imposed upon the diaphragm by the compensating weight, substantially as set forth.

4. In a phonographic recording device, the combination with a diaphragm, of a compensating weight, a recorder connected with the diaphragm and said compensating weight, and an adjustable spring connected with the diaphragm for counteracting the stress imposed upon the diaphragm by the compensating weight, substantially as set forth.

5. In a phonographic recording device, the combination with a diaphragm, a compensating weight and recording devices interposed between the diaphragm and said weight, of an auxiliary spring carried by said weight and connected with the recording devices, substantially as set forth.

6. In a phonographic recording device, the combination with a diaphragm, a compensating weight and recording devices interposed between the diaphragm and said weight, of an auxiliary spring carried by said weight and connected with the recording devices, and means for adjusting the tension of said auxiliary spring, substantially as set forth.

7. In a phonographic recording device, the combination with a diaphragm, of a compensating weight, a recording-lever pivoted to said weight and carrying at one end a cutting or engraving tool, a link connecting the other end of said lever with the diaphragm, and an adjustable spring carried by the compensating weight and connected at its free end to the working end of the recording-lever, substantially as set forth.

This specification signed and witnessed this 10th day of February, 1899.

THOMAS A. EDISON.

Witnesses:

ALEXANDER ELLIOTT, Jr.,  
JOHN F. RANDOLPH.