

No. 703,051.

Patented June 24, 1902.

T. A. EDISON.
ELECTRIC METER.

(Application filed Oct. 15, 1900.)

3 Sheets—Sheet 2.

(No Model.)

Fig. 2

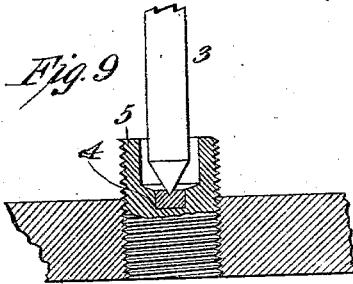
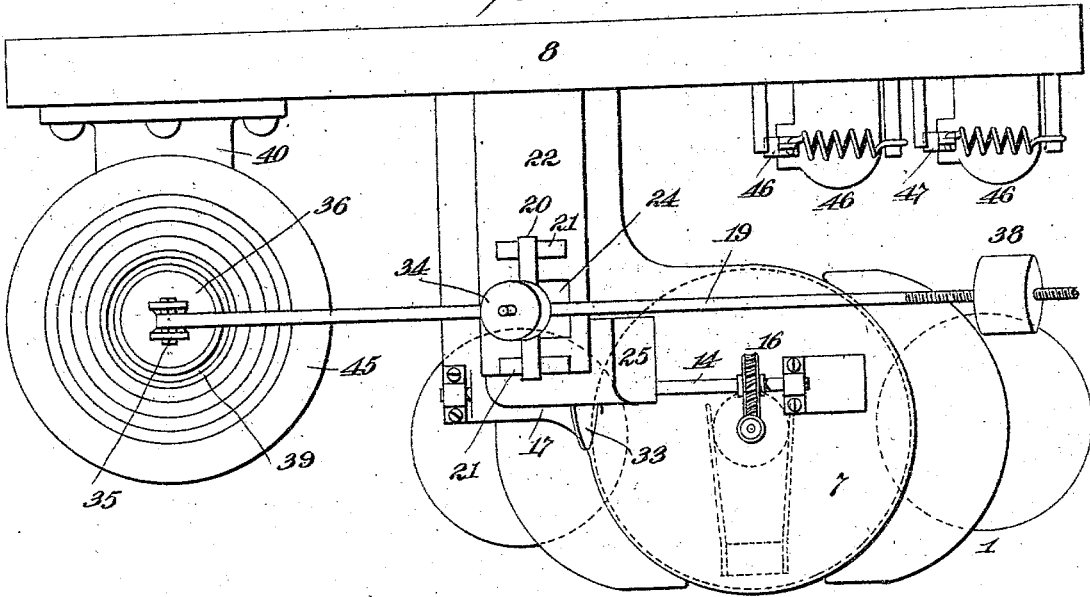

Fig. 3

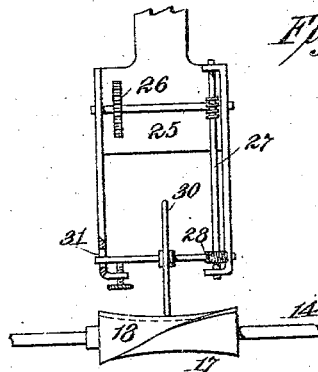

Fig. 4

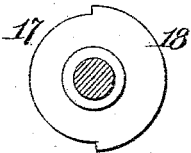

Fig. 5

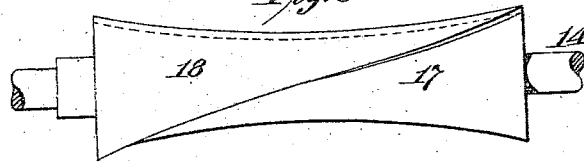
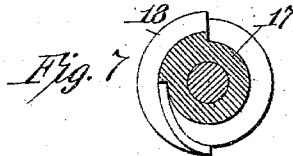
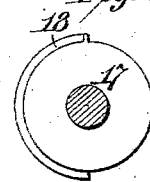

Fig. 6



WITNESSES:

Archibald P. Reese
Geo. A. Taylor

INVENTOR

Thomas A. Edison

BY

Spencer Edmundo and Spence
ATTORNEYS.

No. 703,051.

Patented June 24, 1902.

T. A. EDISON.
ELECTRIC METER.

(Application filed Oct. 15, 1900.)

(No Model.)

3 Sheets—Sheet 3.

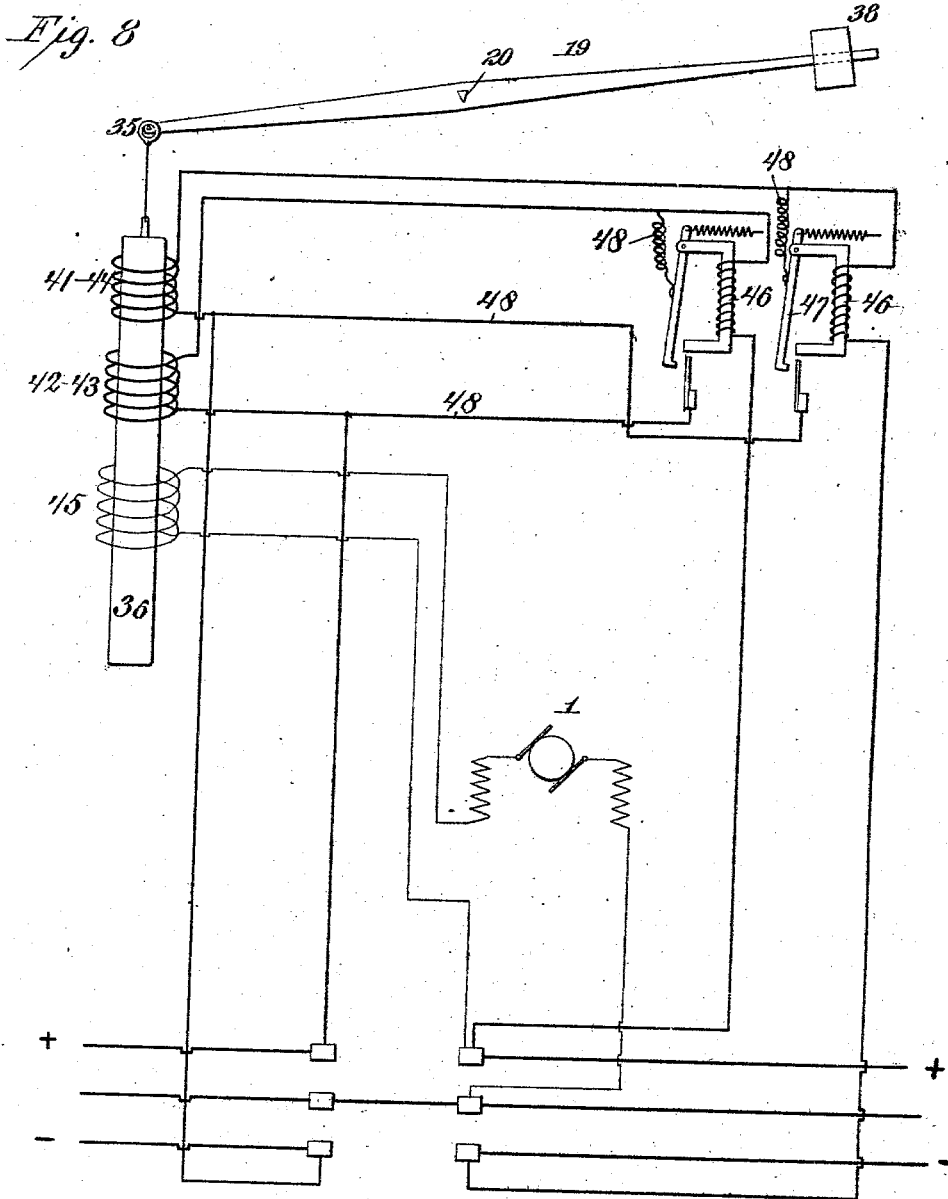

Witnesses:

Archibald H. Rose
Geo. R. Taylor

Inventor

Thomas A. Edison
By R. E. Edwards
Att'ys.

UNITED STATES PATENT OFFICE.

THOMAS A. EDISON, OF LLEWELLYN PARK, NEW JERSEY.

ELECTRIC METER.

SPECIFICATION forming part of Letters Patent No. 703,051, dated June 24, 1902.

Application filed October 15, 1900. Serial No. 33,034. (No model.)

To all whom it may concern:

Be it known that I, THOMAS A. EDISON, a citizen of the United States, residing at Llewellyn Park, in the county of Essex and State of New Jersey, have invented certain new and useful Improvements in Electric Meters, (Case No. 1,047,) of which the following is a description.

My invention relates to various new and useful improvements in electric meters of the type described in my patent dated October 23, 1900, No. 660,293, wherein is employed a constant speed-motor, which drives a register at a speed substantially proportional to the current consumed. In my said patent I described as a specific embodiment of the invention an electric motor the speed of which was maintained constant by a centrifugal speed-governor, the motor driving one element of a frictional variable-speed gearing, the other element of which was connected to the register, and the relative positions of such gear elements being determined by an ampere-indicator directly influenced by the current to be measured. With said meter I provided means for periodically separating the two co-operating elements of the variable-speed gearing in order that the ampere-indicator might be free to respond to variations in the consumed current and not be subject to the frictional engagement of such co-operating elements.

My present improvements are designed to simplify the construction and increase the efficiency of an electric meter of the specific type described in said patent.

The improvements relate, first, to the construction of a centrifugal speed-governor for the electric motor, by means of which its efficiency and durability will be increased; second, to improvements in the construction and arrangement of the ampere or other current indicator; third, to the use of cut-out devices for short-circuiting the ampere-indicator in the event of destructively-large currents in the circuit; fourth, to an improved manner of connecting the register with the constant-speed motor, whereby during periodic intervals the current-indicator will be free to adjust itself to changes in the load absolutely independent of any friction other than the negligible friction of the knife-edge pivots of

the scale-beam; fifth, to the employment of means whereby may be overcome a slight error due to the magnetic inertia, which I have found to exist in meters of this type in the registration of the first increments of current; sixth, to the doing away in an electric meter of magnetic, electric, or elastic constants, which are necessarily variable, and the employment of gravity only as a constant, and, finally, to various other details in the construction and operation, all as will be more fully hereinafter set forth and claimed.

In order that my invention may be better understood, attention is directed to the accompanying drawings, forming a part of this specification, and in which—

Figure 1 is a front elevation, partly in section, showing the operative parts of my improved meter; Fig. 2, a plan view thereof; Fig. 3, a detail view of the cam and part of the register; Fig. 4, a rear view of the cam; Fig. 5, a side view thereof; Fig. 6, a front end view thereof; Fig. 7, a cross-sectional view thereof; Fig. 8, a diagram of the motor-circuits, and Fig. 9 a detail view of the bottom bearing of the armature-shaft of the electric motor.

In all of the above views corresponding parts are represented by the same numerals of reference.

1 represents an electric motor of any suitable type, the armature 2 of which is mounted on a vertical shaft 3. This shaft is stepped on a block 4, of phosphor-bronze or other hard material, which is received in a vertically-adjustable cup 5 (see Fig. 9) for holding oil, so as to lubricate the shaft, as will be understood. The armature-shaft 3 passes through a bearing 6, carried by a suitable base 7, which in turn is secured to a back plate or bed 8. An arm 9 is secured to the armature-shaft below the bearing 6 and carries at its free ends the bell-cranks 10, having weights 11 at their lower ends. The short arms of the bell-cranks are provided with buffers or friction-pads 12, made, preferably, of fiber, and said pads cooperate with a disk 13, secured to the under side of the base and made of hard smooth material, preferably a glass disk cemented to said base. As the speed of the armature 2 increases the centrifugal weights 11 will swing outwardly, en-

gaging the friction-pads 12 with the surface 13, so as to impose a resistance to the rotative effect, whereby a practically constant speed of the motor-armature will be secured.

5 Mounted in suitable bearings on the base 7 is a shaft 14, which is rotated by the armature-shaft 3 by any suitable gearing, such as a worm 15 and gear 16. This shaft carries a barrel 17, to the periphery of which is secured a cam 18 of the generally triangular form shown. The cam 18 may be separated from the barrel 17 or be integral therewith, as will be understood. Obviously so much of the barrel 17 as is not coincident with the cam 18 may be dispensed with. Furthermore, the barrel 17 may be entirely dispensed with and the cam supported in other ways from the shaft 14. Said cam is curved longitudinally on the arc of a circle struck from the pivot of a scale-beam 19. The pivots of this beam are formed by knife-edges 20, bearing on lugs 21, carried by an arm 22, which arm is rigidly secured to the plate 8. Depending from the beam 19 is an arm 23, which works in an opening 24 in the arm 22, and carried by the arm 23 at its lower end is a register 25 of any suitable and appropriate type. This register may be operated from a gear 26, driven, for instance, through a worm connection from a vertical shaft 27, as shown in Fig. 3. The shaft 27 is preferably provided near its lower end with a gear 28, which is engaged with and driven by a worm 29 on a shaft 30. The end of the shaft 30 opposite the worm 29 is carried in a slotted bearing 31 and rests upon an adjusting-screw 32. The engagement between the worm 29 and gear 28 is such as to permit the free end of the shaft 30 to move slightly in the slotted bearing 31 and away from the adjusting-screw 32 without cramping or otherwise affecting the driving operation between the shafts 30 and 27. Carried by the shaft 30 is a friction-wheel 33, which is adapted to be periodically engaged and rotated by the cam 18 as the latter passes beneath said friction-wheel. As the friction-wheel is caused to engage different portions of said cam under the effect of the current to be measured, as will be described, said wheel will be driven through different arcs to operate the register intermittently at a speed proportional to the current consumed.

The register 25 and the elements carried thereby are preferably counterbalanced by counterbalance-weights 34. Connected to the scale-beam at one end by means of a knife-edge connection 35 is a core 36 of an ampere-indicator, said core being made, preferably, of the purest Norway iron. In order that this core may be made as light as possible, it is preferably hollow, as indicated, and may be provided at its ends with plugs 37. At the opposite end of the scale-beam is an adjusting-weight 38, which sufficiently counteracts the weight of the core 36 as will permit the latter to be moved to extents propor-

tional to the current consumed when the coils to be referred to are energized by such current. The ampere-indicator coils just mentioned are wound, preferably, on a copper tube 39, which is suitably carried by a support 40, secured to the plate 8. The meter illustrated is intended specifically for use on a three-wire system, in which case each of the outside wires (see Fig. 8) is in series with one solenoid-coil or set of solenoid-coils which are wound on the tube 39. Preferably with the three-wire meter these coils are arranged in the four sets 41, 42, 43, and 44, as shown in Fig. 1, each set being formed of a single layer of comparatively coarse insulated wire helically wound in position. The outside coil 41 is connected with the inside coil 44, as shown, and said coils are arranged in series, for example, with the negative main, as shown, while the inner coils 42 and 43 are connected together and are arranged in series with the other main. By this arrangement the combined magnetic effect on the core 36 of the coils 41 and 44 is substantially equal to the combined magnetic effect thereon of the coils 42 and 43, whereby corresponding movements of the core 36 will be produced by a corresponding current in either the positive or negative main. This arrangement also enables me to shorten the vertical dimension of the solenoid and to thereby reduce the length and weight of the core. The solenoid coils referred to may be supported upon the tube 39 by means of a split collar 44', as shown, whereby said coils may be also vertically adjustable with respect to said tube. I find in practice that an ampere-indicator comprising one or more solenoid-coils and an overweighted core movable freely therein produces a proportionately-shorter movement of the core when the first increment of current traverses the coil or coils than when added increments of current are caused to traverse said coil or coils, owing to magnetic inertia of the core. Although this error could be compensated by properly changing the form of the cam 18, as will be obvious, I prefer to correct it by the employment of a corrective auxiliary coil 45, made of very fine wire and wound, preferably, on the outside of the ampere-coils and to arrange the same, as shown, in series with the motor 1 across the line from one of the outside wires to the neutral wire, as shown, or between both of the outside wires, as will be obvious. I find in practice that the minute current necessary to operate the motor 1 and which traverses the corrective coil 45 tends to overcome the magnetic inertia of the core 36, so that the latter becomes proportionately responsive to the currents influencing the ampere coil or coils. In order to prevent injury to the delicate moving parts of the meter should the latter be subject to a destructive current, as might occur in the case of a short circuit beyond the meter, I prefer to employ a magnetic cut-out device 46 for each outside main in a three-wire circuit or for one of the mains

of a two-wire circuit, and the armature 47 of each of which when attracted is adapted to close a shunt 48 around the ampere-coils, each shunt including the said armature, as shown. In order to limit the extreme movements of the core 36, I preferably employ elastic buffers 49, which are carried by arms 50, secured to the plate 8 above and below said core, as shown.

The operation of my improved meter is as follows: Normally the friction-wheel 33 will be almost in engagement with the narrow end of the cam 18. When the meter is properly connected up for use with the motor in multiple, the latter will commence to operate until its speed reaches the desired point, whereupon such speed will be maintained constant by the centrifugal speed-governor described. The slight current which traverses the motor also influences the corrective coil 45 to overcome the magnetic inertia of the core 36, so that when any current influences the ampere-coils on either or both the outside mains the core 36 will be attracted to the proper proportionate extent, swinging the scale-beam 19 on its pivot and causing the friction-wheel 33 to be engaged by the proper part of the cam 18 as to give the desired rate of registration. This movement of the scale-beam 19 under the influence of the current to be measured can take place without resistance during that portion of the rotation of the shaft 14 when the cam is withdrawn from engagement with the friction-wheel, as will be understood. At this time it will be obvious that the ampere-indicator will be free to adjust itself to the current to be measured absolutely independent of any friction other than the negligible friction imposed by the knife-edge pivots 20. At each rotation of the shaft 14, therefore, the cam 18 will engage the friction-wheel 33 to move the same in a smaller or larger arc, according to the current to be measured, and in this engagement between the cam and the friction-wheel the latter will be slightly elevated to lift the free end of the shaft 30 from the adjusting-screw 32, the shaft falling back upon such adjusting-screw after the cam has ceased to engage the friction-wheel. By thus regulating the adjusting-screw 32 so that the lower edge of the friction-wheel will be slightly below the plane of the cam 18, whereby the latter will slightly elevate the friction-wheel at each engagement therewith, I do away with the necessity of securing a constant and delicate adjustment between the cam and friction-wheel and at the same time prevent the possibility of any lost motion due to ordinary wear of either of said elements. By winding the solenoid-coils upon a copper tube, as explained, I dampen or make sluggish the movements of the core 36, (without, however, affecting the accuracy of the indicator,) owing to the generation of Foucault currents in said tube due to variations in the strength of said coils produced by changes in

the current to be measured. When a destructive current traverses the circuit, as may occur in the case of a short circuit beyond the meter, the magnetic cut-out or cut-outs will close one or both of the shunts 48 to short-circuit the ampere-coils. By reason of the generation of Foucault currents in the copper tube 39, due to the presence in the ampere coil or coils of such a destructive current, the dampening effect referred to will be sufficient to prevent the core 36 from immediately responding thereto, and in consequence the ampere coil or coils will be short-circuited before the core is moved to an objectionable extent. In this movement the core will engage the buffers 49, but not with sufficient force to dislodge the pivots of the beam. If means were not employed for dampening or making sluggish the movements of the core, the latter would be moved to its full extent under the influence of the destructive currents before the coil or coils could be short-circuited and there would be danger of the pivots of the scale-beam becoming dislodged or the meter otherwise damaged.

Having now described my invention, what I claim as new, and desire to secure by Letters Patent, is as follows:

1. In an electric meter, the combination with an overbalanced beam, a core connected to one end of said beam, a stationary coil surrounding said core and traversed by the current to be measured, a register connected to and movable with the beam, and a friction-wheel movable with the beam and connected with said register, of a cam with which said friction-wheel periodically cooperates, and an electric motor connected across the line for rotating said cam at a constant speed, substantially as set forth.
2. In an electric meter, the combination with an overbalanced beam, a core connected to one end of said beam, a stationary coil surrounding said core and traversed by the current to be measured, a register connected to and movable with the beam, and a friction-wheel movable with the beam and connected with said register, of a cam with which said friction-wheel periodically cooperates, an electric motor connected across the line for rotating said cam at a constant speed, and an auxiliary coil of high resistance surrounding the core for overcoming magnetic inertia without producing saturation or polarization thereof, substantially as set forth.
3. In an electric meter, the combination with an overbalanced beam, a core connected to one end of said beam, a stationary coil surrounding said core and traversed by the current to be measured, a register connected to and movable with the beam, and a friction-wheel movable with the beam and connected with said register, of a cam with which said friction-wheel periodically cooperates, an electric motor connected across the line for rotating said cam at a constant speed, and an aux-

iliary coil of high resistance surrounding the core for overcoming magnetic inertia without producing saturation or polarization thereof, said core being in series with the motor, substantially as set forth.

4. In an electric meter, the combination with a beam, a current-indicator for moving said beam, a magnetic cut-out in series with the current-indicator for short-circuiting the latter when a destructive current traverses the cut-out, and a register connected to and movable with the beam, of a variable-speed gearing, one element of which is movable with the register, and a motor for operating the other element of said gearing, substantially as and for the purposes set forth.

5. In an electric meter, the combination with a current-indicator having a movable element, a beam to which said element is connected, elastic buffers for limiting the extreme movements of said element, and a register, of a variable-speed gearing the position of whose elements is determined by the position of said beam, and a motor for driving the register through said variable-speed gearing, substantially as set forth.

6. In an electric meter, the combination with a beam, a core connected to one end of said beam, a copper tube surrounding said core and in which the core is freely movable, an ampere-coil wound on the tube and traversed by the current to be measured, and a register, of a variable-speed gearing the position of whose elements is determined by the position of said beam, and a motor for driving the register through said variable-speed gearing, substantially as set forth.

7. In an electric meter, the combination with a beam, a core connected to one end of said beam, a copper tube surrounding said core and in which the core is freely movable, an ampere-coil wound on the tube and traversed by the current to be measured, elastic buffers for limiting the extreme movements of said core, and a register, of a variable-speed gearing the position of whose elements is determined by the position of said beam, and a motor for driving the register through said variable-speed gearing, substantially as set forth.

8. In a three-wire meter, the combination with a beam, a core connected to one end of said beam, a copper tube surrounding said core and within which the core is freely movable, four ampere-coils wound helically and concentrically upon said tube, the outer and inner coils being connected in series with one of the outside mains and the two inner coils being connected in series with the other outside main, and a register, of a variable-speed gearing the position of whose elements is determined by the position of said beam, and a motor for driving said register through said variable-speed gearing, substantially as set forth.

9. In an electric meter, the combination with a beam, a core connected to one end of

said beam, an ampere-coil surrounding the core and traversed by the current to be measured, and a register, of a variable-speed gearing the position of whose elements is determined by the position of said beam, a motor for driving said register through said variable-speed gearing, and an auxiliary coil inclosing the core for overcoming the magnetic inertia thereof without producing saturation or polarization, substantially as set forth.

10. In an electric meter, the combination with a beam, a core connected to one end of said beam, an ampere-coil surrounding the core and traversed by the current to be measured, and a register, of a variable-speed gearing the position of whose elements is determined by the position of said beam, a motor for driving said register through said variable-speed gearing, and a stationary auxiliary coil inclosing the core and in series with said motor, substantially as set forth.

11. In an electric meter, the combination with a beam, an ampere-indicator the movable element of which is connected with said beam, said indicator including a coil traversed by the current to be measured, a register, and a motor for operating said register, of a magnetic cut-out arranged to close a shunt around the ampere-coil when said cut-out is influenced by an abnormal current, substantially as set forth.

12. In an electric meter, the combination with a register, an ampere-indicator, and a variable-speed gearing the position of whose elements is determined by said indicator, of a constant-speed motor for driving the register through the variable-speed gearing, and a centrifugal speed-regulator for said motor employing a weighted bell-crank carrying a friction-pad which coöperates with a glass friction-surface, substantially as set forth.

13. In an electric meter, the combination with a register and a driving-motor, of an ampere-indicator comprising a beam, a core connected to one end of said beam, a coil for influencing the core traversed by the current to be measured, and a copper tube on which the coil is wound and in which the core is freely movable, substantially as set forth.

14. In an electric meter, the combination with a register and a driving-motor, of an ampere-indicator comprising a beam, a core connected to one end of said beam, a coil for influencing the core traversed by the current to be measured, a copper tube on which the coil is wound and in which the core is freely movable, and elastic buffers for limiting the extreme movements of said core, substantially as set forth.

15. In an electric meter, the combination with a register and a driving-motor, of an ampere-indicator comprising a beam, a core connected to one end of said beam, a coil for influencing the core traversed by the current to be measured, a magnetic cut-out in circuit with said coil for shunting the same when a destructive current is traversing the coil, and a

copper tube on which the coil is wound and in which the core is freely movable, substantially as set forth.

16. In an electric meter, the combination
5 with a register and a motor for operating the same, of an ampere-indicator comprising a coil, a core, and an auxiliary coil for subjecting the core to an initial magnetizing effect

without producing polarization or saturation thereof, substantially as set forth.

This specification signed and witnessed this
28th day of September, 1900.

THOMAS A. EDISON.

Witnesses:

FRANK L. DYER,

JNO. R. TAYLOR.