

No. 713,863.

Patented Nov. 18, 1902.

T. A. EDISON.
PROCESS OF COATING PHONOGRAPH RECORDS.

(Application filed June 16, 1900.)

(No Model.)

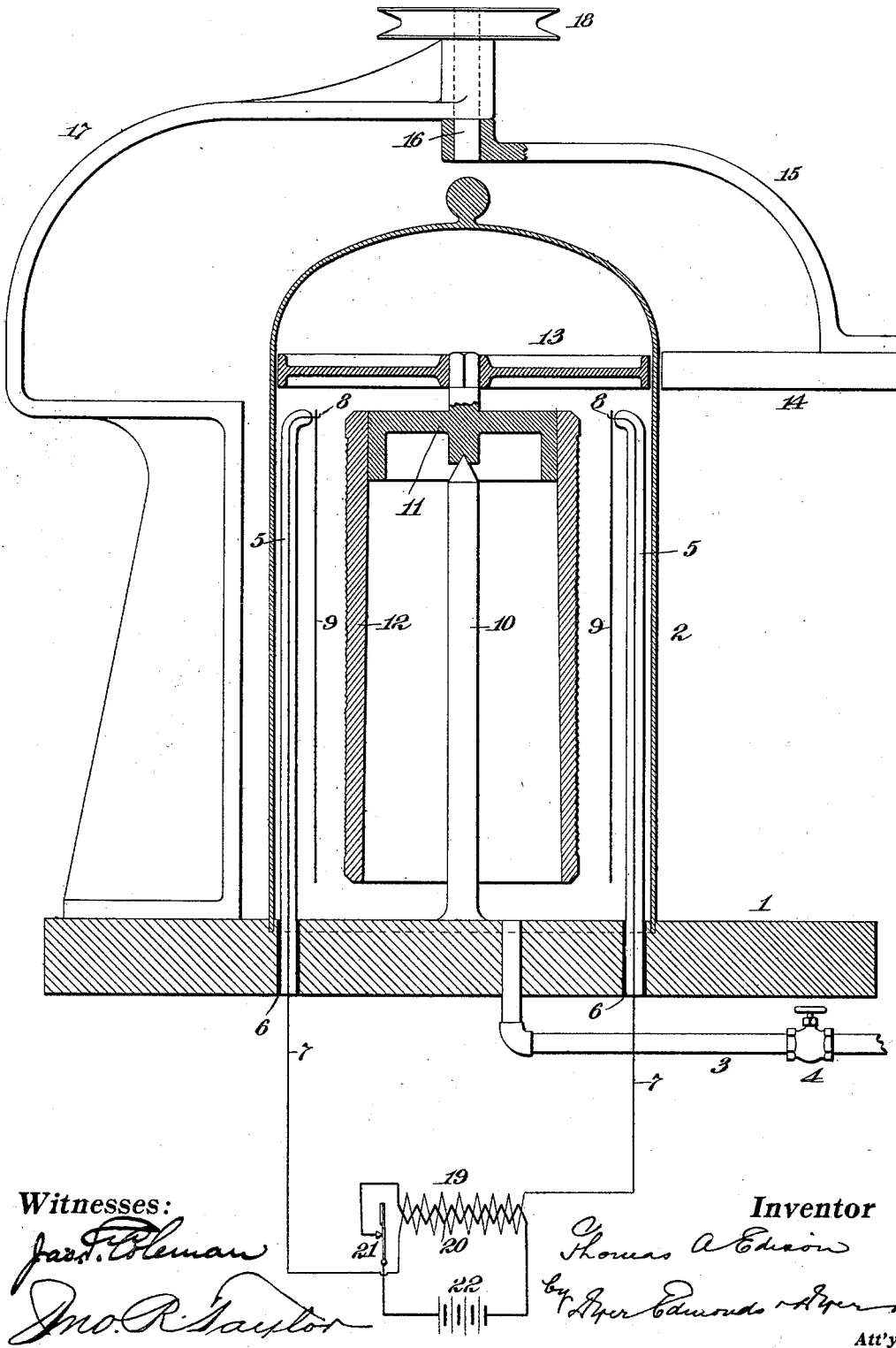

Witnesses:

Jas. P. Coleman

Geo. R. Taylor

Inventor

Thomas A. Edison
By Geo. Edwards Rogers

Att'ys.

UNITED STATES PATENT OFFICE.

THOMAS A. EDISON, OF LLEWELLYN PARK, NEW JERSEY.

PROCESS OF COATING PHONOGRAPH-RECORDS.

SPECIFICATION forming part of Letters Patent No. 713,863, dated November 18, 1902.

Application filed June 16, 1900. Serial No. 20,555. (No specimens.)

To all whom it may concern:

Be it known that I, THOMAS A. EDISON, a citizen of the United States, residing at Llewellyn Park, in the county of Essex and State of New Jersey, have invented a certain new and useful Process of Coating Phonograph-Records, (Case No. 1,038,) of which the following is a specification.

My invention relates to an improved process of the general type described by me in my Patent No. 526,147, dated September 18, 1894, my process being adapted for covering phonograph-records with an infinitesimally thin film of metal on which a heavier coating can be obtained by electrodeposition in order that a matrix or mold of the record can be secured for subsequent use in processes of duplicating such records.

The value of my process for the coating of phonograph-records resides in the fact that the deposited film is so minutely thin as to be accurately deposited upon all portions of the record, so that an absolutely accurate matrix or mold can be secured.

In my patent in question I describe a process of securing a metallic deposit upon any desired material, consisting in maintaining the material in an exhausted atmosphere and in securing the deposit by the formation of a practically continuous arc between two bodies of the metal of which the deposit is to be made, whereby said metal will be vaporized and the vapor deposited upon the desired material. I find in practice that the employment of an electric arc for vaporizing the metal, as suggested in my patent, is open to the objection of being slow, and unless the process is carried on with great care the deposit is not entirely uniform, while there is danger of injuring the very delicate phonographic-record surface, particularly from the heat of the arc. I find that the rapidity of the process is increased and the character of the deposit improved if the vaporization of the metal is effected by maintaining between two electrodes of the metal a silent discharge of electricity of high tension, such as may be produced from an induction-coil of large capacity or from any induction-machine of improved type, such as the Helmholtz induction-machine. The creation of a silent or practically silent discharge between two electrodes

results in the vaporization of the metal and its rapid and more direct deposit upon a phonograph-record supported between the electrodes than is the case in the patent. When a silent discharge is effected between the electrodes, the vaporized metal is carried by the discharge directly toward and upon the record to be coated. Instead of establishing a silent discharge between the electrodes a brush discharge may be maintained between them for securing the same result.

In effecting the coating of a metal upon the phonograph-record uniformity is secured by rotating the latter with respect to the electrodes. My present invention contemplates, therefore, the rotation of the record to be coated with respect to the electrodes in order that this result may be secured. Since the proper vaporization of the metal is effected only in the presence of a vacuum, preferably of high degree, I prefer in the carrying out of my process to effect the rotation of the record to be coated by a magnet movable exteriorly of the vacuum-chamber and attracting an armature connected to the object, and my present process in its preferred form contemplates such an operation.

In order that my process may be better understood, attention is directed to the accompanying drawing, forming part of this specification, and which shows an improved apparatus for carrying my process into effect.

1 represents a base, and 2 a vacuum chamber or jar, fitted with an air-tight joint upon the base.

3 is a pipe connected to the interior of the jar and by means of which air may be exhausted therefrom in any suitable way, as by an air-pump or by a Sprengel vacuum-pump, the latter being preferable, since a high vacuum is desirable in the operation. When the vacuum has been secured, it is retained by closing a valve 4 in the pipe 3 or by maintaining the vacuum-pump in constant operation.

5 5 represent two supporting-arms, made, preferably, of glass and leading up within the interior of the jar or vacuum-chamber, said supporting-arms being preferably further insulated from the base by means of hard-rubber insulating-bushings 6. A conductor 7 leads up within each of the support-

ing-arms and is formed with a hook 8 at its upper end. Suspended from each hook is an electrode 9 of the metal, preferably gold, to be deposited upon the record to be coated, such electrodes being preferably in the form of thin wires or strips of foil of such metal.

10 is a standard mounted between the electrodes and carrying a rotatable head 11 at its upper end, said head having a tapered periphery, from which is supported a phonograph-record 12, having a tapered bore, as is common. The record may be supported in any other way.

13 is an iron or steel armature carried by the rotatable head 11 and adapted to be attracted by a magnet 14, rotatable on the exterior of the vacuum-chamber. An ordinary horseshoe-magnet may be conveniently used for the purpose. I illustrate the magnet 14 as being supported by an arm 15 from a shaft 16, carried by a suitable bracket 17 and rotated by a pulley 18.

In operation a silent or brush discharge is established between the electrodes 9 in any suitable way—as, for example, by connecting the conductors 7 with the secondary of a large induction-coil 19, the primary 20 of which is included in a vibrator 21 and a source of current 22. The brush or silent discharge being established between the electrodes and the magnet 14 being rotated on the exterior of the vacuum-chamber to attract the armature 13, the record to be coated will be rotated between the electrodes, while the metal vaporized by the discharge will be deposited upon said record in the form of an infinitesimally thin and practically uniform film. When the phonograph-cylinder has been coated, it is removed and placed in a plating-bath, so as to receive a heavier deposit by a process of electrodeposition, after which the original record is removed, either by melting it out or by shrinking it from the deposited metal, whereby an absolutely accurate matrix or mold of the original record is secured.

Having now described my invention, what I claim as new, and desire to secure by Letters Patent, is as follows:

1. The process of making a matrix or mold of a phonograph-record, which consists in maintaining the record in an exhausted chamber in proximity to an electrode of the metal of which the deposit is to be made, and in establishing a silent or brush electrical discharge between said electrode and a second electrode placed on the other side of the phonograph-record whereby the latter will be located between said electrodes, substantially as set forth.

2. The process of making a matrix or mold of a phonograph-record, which consists in maintaining the record in an exhausted cham-

ber between two electrodes of the metal of which the deposit is to be made, and establishing a silent or brush electrical discharge between said electrodes, substantially as set forth.

3. The process of making a matrix or mold of a phonograph-record, which consists in rotating the record in an exhausted chamber between two electrodes of the metal of which the coating is to be secured, and maintaining between said electrodes a silent or brush electrical discharge, substantially as set forth.

4. The process of making a matrix or mold of a phonograph-record, which consists in supporting the record in an exhausted chamber between two electrodes of the metal to be deposited, in establishing a silent or brush electrical discharge between said electrodes, and in rotating the record magnetically from the exterior of the chamber, substantially as set forth.

5. The process of making a matrix or mold of a phonograph-record, which consists in maintaining the record in an exhausted chamber in proximity to a metallic electrode, in establishing a silent or brush electrical discharge between said electrode and a second electrode placed on the other side of the record whereby the latter will receive a metallic deposit, then in electroplating on said metallic deposit, and finally in removing the original record from the matrix so secured, substantially as set forth.

6. The process of making a matrix or mold of a phonograph-record, which consists in maintaining a phonograph-record in an exhausted chamber between two metallic electrodes, establishing a silent or brush electrical discharge between said electrodes whereby a metallic coating will be deposited on the record, then in electroplating upon said metallic coating, and finally in removing the phonograph-record from the matrix so secured, substantially as set forth.

7. The process of making a matrix or mold of a phonograph-record, which consists in rotating a phonograph-record in an exhausted chamber between two metallic electrodes, in maintaining between said electrodes a silent or brush electrical discharge whereby a metallic coating will be deposited on said record, then in electroplating upon said metallic coating, and finally in removing the record from the matrix so secured, substantially as set forth.

This specification signed and witnessed this 15th day of May, 1900.

THOMAS A. EDISON.

Witnesses:

J. F. RANDOLPH,
W. MALLORY.