

No. 880,484.

PATENTED FEB. 25, 1908.

T. A. EDISON.

PROCESS OF PRODUCING VERY THIN SHEET METAL.

APPLICATION FILED JUNE 29, 1904.

2 SHEETS—SHEET 1.

Fig. 1.

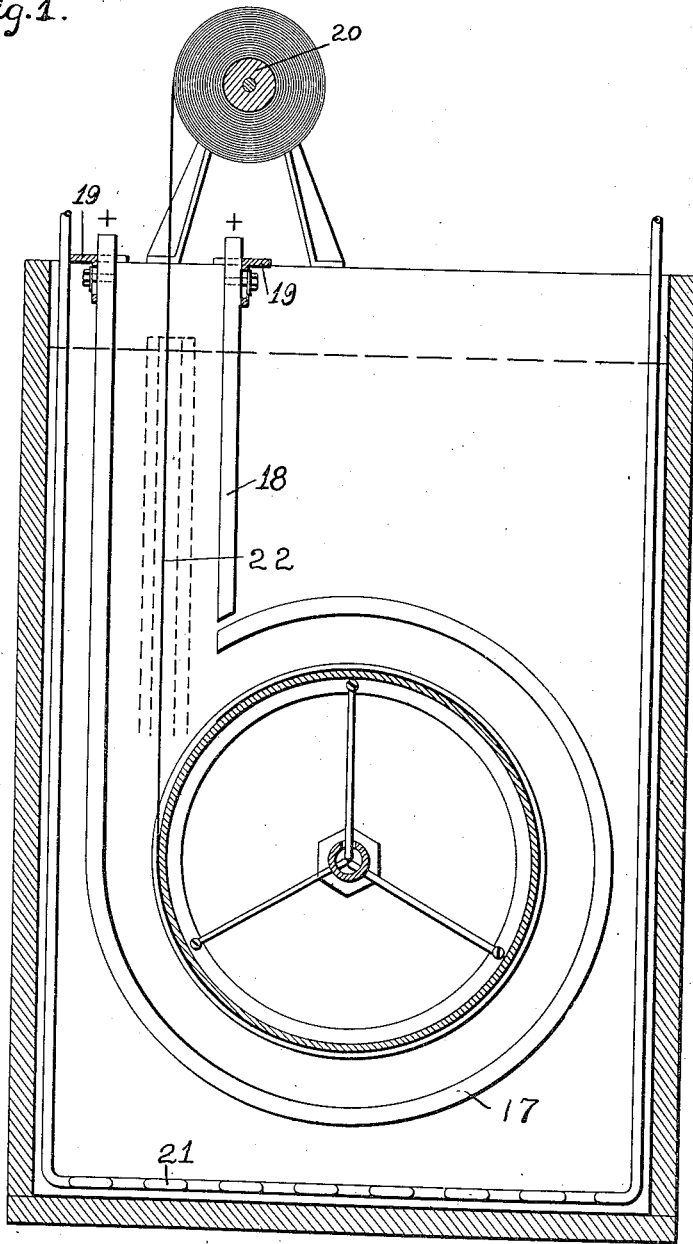

Witnesses:

*Maria C. Mac Arthur*  
*Harry S. Walter*

Inventor

*Thomas A. Edison*  
by *Frank L. Ryan*  
Attorneys.

No. 880,484.

PATENTED FEB. 25, 1908.

T. A. EDISON.  
PROCESS OF PRODUCING VERY THIN SHEET METAL.  
APPLICATION FILED JUNE 29, 1904.

2 SHEETS—SHEET 2.

*Fig. 2*

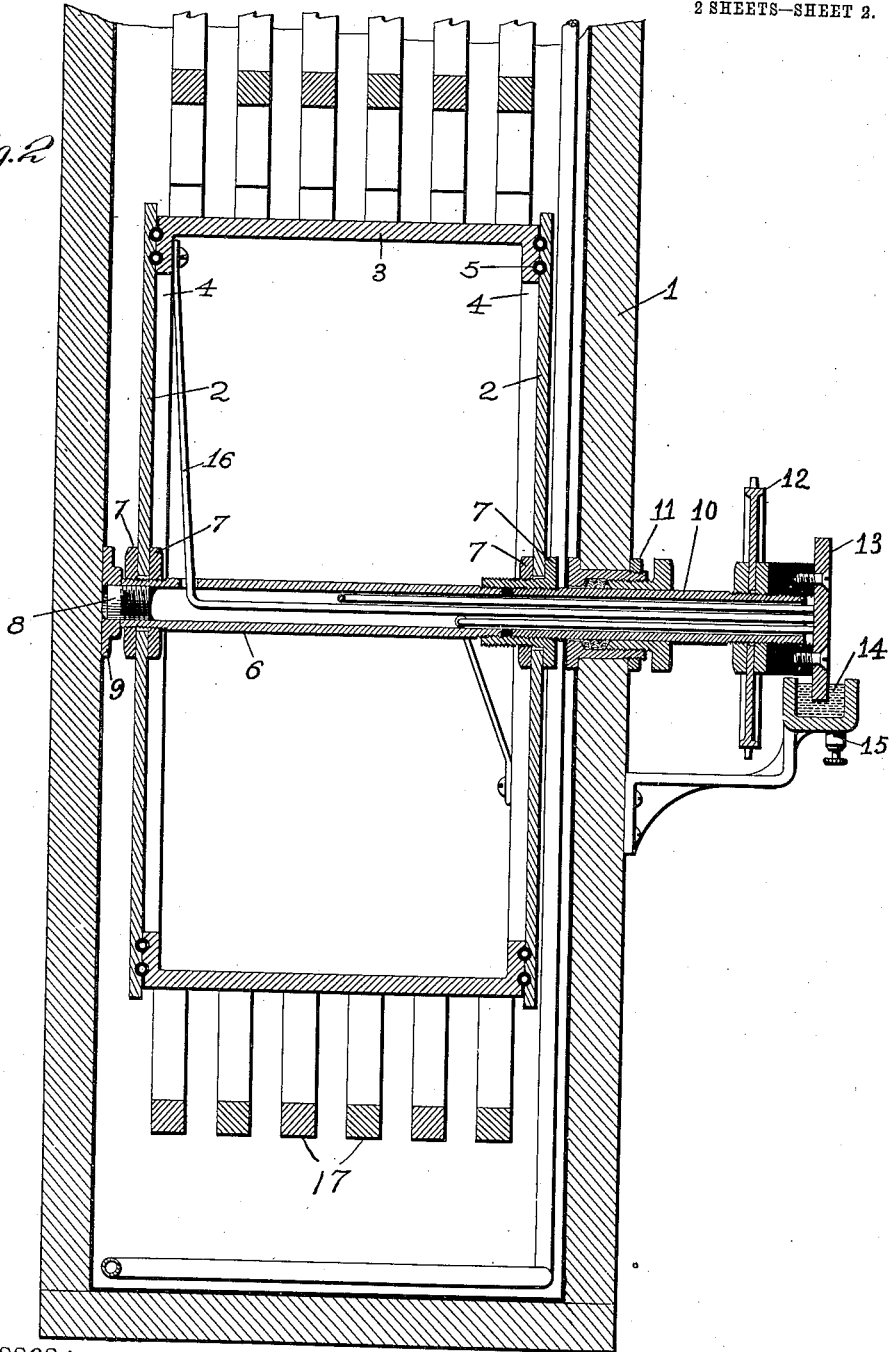

Witnesses:

*Mina C. McArthur*  
*Harry S. Hatten*

Inventor

*Thomas A. Edison*  
*By Frank L. Spier*  
Attorneys.

# UNITED STATES PATENT OFFICE.

THOMAS A. EDISON, OF LLEWELLYN PARK, ORANGE, NEW JERSEY, ASSIGNOR TO EDISON STORAGE BATTERY COMPANY, OF WEST ORANGE, NEW JERSEY, A CORPORATION OF NEW JERSEY.

## PROCESS OF PRODUCING VERY THIN SHEET METAL.

No. 880,484.

Specification of Letters Patent.

Patented Feb. 25, 1908.

Application filed June 29, 1904. Serial No. 214,651.

*To all whom it may concern:*

Be it known, that I, THOMAS A. EDISON, a citizen of the United States, residing at Llewellyn Park, Orange, Essex county, State of New Jersey, have invented a certain new and useful Improved Process for Producing Very Thin Sheet Metal, of which the following is a description.

My invention relates to an improved method, or process, for producing ribbons of sheet metal of extreme thinness at low cost. At the present time, the only method in practical use for manufacturing thin sheets of metal is by the use of heavy rolls, which gradually reduce the billet to the desired thinness.

I am of course, aware that for the production of gold foil, and other metal foils, beating operations with hammers are followed, but such a process is necessarily confined within a very limited field, and cannot compete in cost of product, with the rolling operation. In a rolling process, the reduction in thickness, which may be effected at each pass between the rolls, is relatively small, and in case of most useful metals, is limited by the loss in ductility, caused by continued change of its shape. Consequently, in rolling metals, it becomes necessary to reestablish the ductility by annealing the material, and eventually removing the scale of oxid formed during the annealing operation. For this reason, the cost per pound of rolled sheet metal increases very rapidly as the thickness of the sheet decreases, so that in case of very thin sheets, the original cost of the bulk material forms only a small fraction of the cost of the completed product. In order to avoid these repeated and expensive rolling, annealing and reducing operations, and to obtain directly from a cheap raw material, a product of the desired thickness and shape, I cause the metal to be deposited out of an electrolyte upon a suitable cathode, the surface of which possesses the property of allowing the deposit, when it has reached the desired thickness, to be readily and continuously detached without injury either to the cathode or to the deposit itself. In this way, the cost of the product is directly proportional to its weight, and is determined by the price of the raw material and the cost of the operations followed. Hence, in dealing with any particular metal, it becomes possible to

determine a particular thickness of sheet which can be obtained for the same cost by my improved process, or by the usual rolling process; so that in making thicker sheets, a rolling process will be preferable on account of cheapness, while in making thinner sheets, the product can be more economically obtained by my improved process and apparatus. Manifestly the economies secured by carrying my improved process into effect will be relatively increased in making sheets that are materially thinner than that at which the two processes are on substantially the same footing as to cost of operation.

As the result of very extensive experiments, I have found that surfaces from which a metallic electrolytic deposit may be as readily and cleanly stripped, may be formed of a number of metals, such as iron, copper, nickel and silver, if in a highly polished condition, and especially when there is present a microscopic layer of foreign matter, like oxids, grease or graphite. I find, however, that this property is possessed to a superior and remarkable degree by aluminium and its alloys. With these materials, I attribute the special property to the fact that the thin scale of oxid, that in all solutions forms upon the surface of aluminium and its alloys, and which is instantaneously regenerated if ruptured, permits the ready and clean separation of the deposited metal from a cathode formed of aluminium or its alloys. With pure aluminium, this tendency of forming an oxid is so strong, that a moment's exposure to air, or a short interruption of the current allows the formation of a prohibitively large amount of oxid for securing a good deposit; and for this reason I prefer to employ an alloy of aluminium instead of the pure metal. I have obtained excellent results in practice with an alloy consisting of 95 per cent. of copper and 5 per cent. of aluminium.

In carrying my invention into effect, I may secure the deposit upon separate sheets, from which the deposited films are stripped intermittently, but preferably, I employ an endless surface moving slowly through the electrolytic bath and upon which the metal is continuously deposited and from which the deposited film is being continuously stripped off, so that the process is a continuous one and may be carried out for the production of metallic films many hundreds of feet in length. Such an endless surface may be pre-

sented by an endless metallic belt, running over rollers of large diameter, and receiving a metallic deposit on one or both of its sides, but I preferably employ a drum for this purpose, presenting a smooth outer surface on which the deposit takes place.

In order that the invention may be better understood, attention is directed to the accompanying drawings forming a part of this specification, and in which

Figure 1 is a longitudinal sectional view of an apparatus suitable for the practice of my improved method, and Fig. 2, a partial sectional view of the same on a larger scale.

In these views, corresponding parts are represented by the same numerals of reference.

The tank 1 is made of any suitable insulating material, such as wood or slate, and is of the desired capacity. Mounted to rotate in this tank is a drum, formed of disks 2—2, and with its cylindrical portion 3 having flanges 4—4. The cylindrical portion 3 of the drum is insulated from the disks 2—2 thereof by a rubber insulator 5, interposed between the flanges 4—4 and said disks, as shown. The drum as a whole, is assembled upon a sleeve 6, on which are mounted nuts 7—7, between which the disks are clamped. One bearing for the drum is formed by a pin 8, engaging the socket 9 on one of the side walls of the tank, and the other bearing is formed by a hollow shaft 10, which passes through a stuffing box 11 to prevent leakage around said shaft. The shaft is rotated in any suitable way, as by power connections engaging the sprocket wheel 12. In practice, the gearing is of such a character that the drum is rotated with great slowness, and I have successfully experimented with apparatus for the purpose in which the peripheral speed of the drum is about one foot in thirty minutes.

The cylindrical portion 3 of the drum constitutes the cathode, and is electrically connected to the proper source of supply in any suitable way, as for example, by means of a contact disk 13, carried by the end of the shaft 10, but insulated therefrom, and dipping in a mercury cup 14, having a binding post 15, by which the proper connection is made. The contact disk 13 is connected electrically to the cylindrical portion 3 of the drum by one or more insulated wires 16.

The anodes 17 are preferably bars of metal, which is to be deposited, extending partly around the drum, as shown, and substantially equidistant therefrom, and preferably supplemented by auxiliary anodes 18, arranged as shown, in order that the deposit may continue on to the strip after the latter has been stripped from the drum, and so long as it may remain in the solution. The anodes 17 and auxiliary anodes 18 are supported from the metal bars 19, with which the proper electrical connections are made.

The strip, after being removed from the surface of the drum is accumulated in any suitable way, as for example, being wound up on a drum 20 rotated by any appropriate mechanism. I find in practice that the results obtained are materially improved by keeping the solution in a heated condition, and this is especially true in making thin strips or sheets of iron. This heating of the solution may be effected in any suitable way, as for example, by a steam coil 21. In some instances also, it is desirable that the solution should be kept in agitation during the electrolytic operation in order to prevent the deposit of insoluble matter, as well as of gas bubbles on the drum, or other surface on which the metal is to be deposited, and for this purpose any suitable agitating devices may be made use of.

Although my improved method is capable of effective use in connection with the making of sheets, or films, of various metals, I have designed it particularly for producing sheets, or films, of iron or steel, or of iron-nickel alloys, or nickel alone, and in order that the method may be understood by those skilled in the art, I will describe it in connection with the production of iron films. For this purpose a 20 per cent. solution of ferrous and ammonium-sulfate is employed, maintained at a temperature of about 85 degrees centigrade throughout, and kept at substantially a constant density.

The anodes 17 and auxiliary anodes 18 are composed of metallic iron. The solution is maintained in the tank 1 quite close to the top thereof. Upon closing the circuit between the anodes, auxiliary anodes, and the drum, and by rotating the drum very slowly as explained, the metal will be homogeneously deposited on the drum at a rate depending obviously upon the current density, and upon the surface speed of the drum. By making the cylindrical portion 3 of the drum of highly polished metal, and particularly of an alloy of copper and aluminium, as explained, the deposit may be stripped from the drum to form a continuous uninterrupted film 22, which is applied to the reel 20 and wound up continuously thereon. After the strip 22 leaves the drum, it is subjected to an additional deposit on each side between the anodes 17 and auxiliary anodes 18, as will be understood. In practice, it will be of course obvious that the deposit will commence to form on the drum immediately in advance of the line at which the strip leaves the drum and will be gradually increased in thickness, as the deposit continues, the rate of increase being augmented after the strip leaves the drum, because at that time the deposit will take place on both sides of the strip. If the entire deposit is secured on the cathode it will be understood of course that the auxiliary anodes 18 may be omitted. In the lat-

ter case it will be desirable to supplement the apparatus by employing a tube made preferably of glass or hard rubber, dipping below the surface of the solution, and through which the strip passes out of the solution as shown in dotted lines Fig. 1. The employment of such a tube or conduit is desirable since there is danger of oxids and other foreign matter floating on the surface of the solution which might contaminate the surface to require a separate washing.

I find that by carrying my improved method into effect I obtain a product which even before annealing is very tough and workable, while, when annealed it compares favorably with the very best of steel and iron, and is practically free from carbon and other elements. I have practically used my improved process in the make-up of my iron-nickel storage battery, wherein active materials are maintained under pressure in perforated pockets composed of thin sheet steel, and for this art, I am enabled to produce sheet metal having the desired characteristics at less cost than by the ordinary rolling operations. It will, however, be understood that other metals may be worked in this way for the production of sheets of any desired degree of thinness and that foil can be obtained which will compare favorably with foil now secured by beating operations.

Having now described my invention, what I claim as new therein, and desire to secure by Letters Patent, is as follows:

1. An improved process for producing metallic sheets or foils, which consists in electrolytically depositing a thin metal film on

a polished surface of an aluminium-copper alloy in which the percentage of copper largely predominates, and in finally stripping the film from said surface, substantially as set forth.

2. The process of producing thin sheets or foils of iron, which consists in electrolytically depositing iron from an iron solution upon a polished surface of an aluminium copper alloy in which the percentage of copper largely predominates, and finally in stripping the deposited film from said surface, substantially as set forth.

3. An improved process for producing metallic sheets or foils which consists in electrolytically depositing a thin metallic film upon an endless polished cathode, in continuously moving said cathode in the electrolytic bath and in continuously stripping the deposited film from said cathode below the surface of the bath, substantially as set forth.

4. An improved process for producing metallic sheets or foils which consists in electrolytically depositing a thin metallic film upon an endless polished cathode situated entirely below the surface of the electrolytic bath, in continuously moving said cathode in the bath and in continuously stripping the deposited film therefrom, substantially as set forth.

This specification signed and witnessed this 24th day of June 1904.

THOS. A. EDISON.

Witnesses:

FRANK L. DYER,  
MINA C. MACARTHUR.