

T. A. EDISON.
STYLUS MOUNTING.
APPLICATION FILED DEC. 11, 1919.

1,425,458.

Patented Aug. 8, 1922.

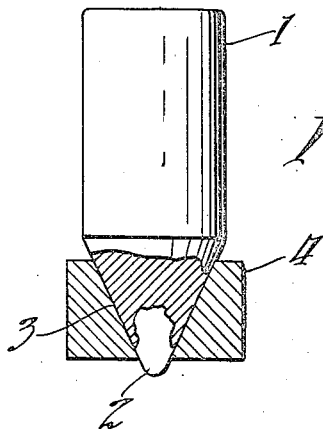

Fig. 1

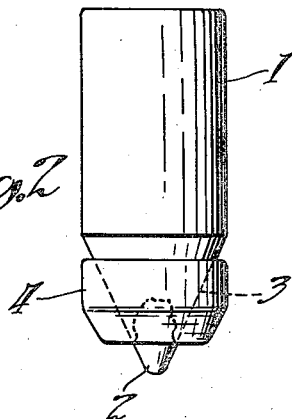

Fig. 2

Witnesses:
N. D. Fisher.
William A. Hardy.

Inventor:
Thomas A. Edison
by Dyer & Holden
Attorneys.

UNITED STATES PATENT OFFICE.

THOMAS A. EDISON, OF LLEWELLYN PARK, WEST ORANGE, NEW JERSEY, ASSIGNOR
TO NEW JERSEY PATENT COMPANY, OF WEST ORANGE, NEW JERSEY, A CORPORATION OF NEW JERSEY.

STYLUS MOUNTING.

1,425,458.

Specification of Letters Patent.

Patented Aug. 8, 1922.

Application filed December 11, 1919. Serial No. 344,093.

To all whom it may concern:

Be it known that I, THOMAS A. EDISON, a citizen of the United States, and a resident of Llewellyn Park, in the town of West Orange, county of Essex, and State of New Jersey, have invented certain new and useful Improvements in Stylus Mountings (Case B), of which the following is a description.

My invention relates to stylus mountings and more especially to mountings for phonographic styli formed of a jewel, such as diamond or sapphire, and in which the stylus is partially enclosed in a metal holder and projects from a reduced end portion thereof.

The principal object of the invention is to provide an improved mounting of this character whereby the stylus will be firmly and rigidly held in its holder so as to effectually prevent the same from being loosened in use.

My invention also resides in the method of reinforcing stylus mountings in order to attain the foregoing object.

More specifically described, my invention consists in applying reinforcing means to the stylus holder at its weakest point, that is, where the jewel or stylus emerges or projects therefrom, such reinforcing means preferably being in the form of a collar forced onto the reduced end portion of the holder to a point just above the projecting portion of the stylus so as to grip the said reduced portion under tension.

Other features of my invention will be hereinafter more fully described and claimed.

In order that my invention may be more clearly understood, attention is directed to the drawing accompanying and forming a part of this specification, and in which:

Figure 1 is an enlarged view in elevation, partly in section, of a reinforcing collar applied to a stylus mounting before the surplus metal of the collar has been removed; and

Figure 2 is an enlarged view in side elevation of a finished stylus mounting embodying my invention.

Referring to the drawing, reference character 1 represents the cylindrical metallic holder of an ordinary form of stylus mounting, and 2 a stylus formed of a diamond splint or other jewel, which is embedded or

enclosed within the holder 1 and projects from one end thereof. The end portion of the holder 1 in which the stylus is embedded is reduced, preferably being tapered down to the projecting end portion of the stylus. As shown herein, the reduced end portion of the holder and the projecting portion of the stylus are formed into a cone portion having a common conical surface, that is, a continuous conical surface formed partly on the holder and partly on the stylus. The end of the stylus 2 is rounded, preferably on an arc having a diameter of about .006", to fit the groove of a phonograph record. It will be apparent that that portion of the holder 1 surrounding the embedded portion of the stylus is quite thin and weak. As a matter of fact, the diamond splint or piece of other jewel employed for the stylus is often of such shape that the portion of the holder adjacent the projecting end portion of the stylus is almost paperlike in thickness. Accordingly, it will be apparent that in the case of many stylus mountings of this character, the styli are very apt to loosen and drop out of their holders in the continued use of the stylus mountings. I have discovered that by properly applying a reinforcing collar to the lower reduced end portion of the holder, this objection may be practically obviated. The reinforcing collar 4 which I have disclosed herein is provided with an opening extending there-through, the wall of which comprises a seat conforming to the reduced conical end portion 3 of the holder 1. In applying the collar 4 to the reduced end portion of the holder 1, the same is first heated to a high degree of temperature and then, while still very hot, is forced onto the said reduced end portion. Accordingly, it will be apparent that upon cooling, the collar 4 will grip the conical reduced end portion of the holder 1 under tension so as to be permanently held thereon by gripping engagement therewith and the stylus 2 will be firmly held in the holder 1 under a high pressure. The collar 4 is then ground down to conform to the cylindrical body portion of the holder 1 and the lower portion thereof is ground to the form shown in Fig. 2. Any surplus metal at the bottom of the collar 4 is then removed in any suitable manner, so as to bare that portion of the stylus 2 which projects from the holder 1.

While I have described a preferred form of reinforced stylus mounting in accordance with my invention, and the preferred method of applying the reinforcing means thereto, it is to be understood that the same are subject to various changes and modifications without departure from the spirit of the invention and the scope of the appended claims.

10 Having now described my invention, what I claim as new and desire to protect by Letters Patent, is as follows:

1. The method of reinforcing a stylus mounting comprising a holder having a reduced end portion and a stylus partially enclosed in the holder and projecting from the end of said portion, which consists in forming a collar with an opening there-
15 through the wall of which conforms to said reduced end portion, heating said collar, and then forcing the same while hot onto the reduced end portion of the holder, substantially as described.

2. The method of reinforcing a stylus mounting comprising a holder having a reduced end portion and a stylus partially

enclosed in the holder and projecting from the end of said portion, which consists in forming a collar with an opening there-
30 through the wall of which conforms to said reduced end portion, heating said collar, forcing the same while hot onto the reduced end portion of the holder, and then removing the surplus metal of the collar so that the projecting portion of the stylus extends
35 below the collar, substantially as described.

3. The method of reinforcing a stylus mounting comprising a holder having a reduced end portion and a stylus partially enclosed in the holder and projecting from the
40 end of said portion, which consists in shrinking a collar onto said reduced end portion, substantially as described.

4. A stylus mounting comprising a holder having a reduced end portion, a stylus partially enclosed in said holder and projecting
45 from the end of said portion, and a collar shrunk on the said reduced end portion, substantially as described.

This specification signed and witnessed this 9th day of December 1919.

THOS. A. EDISON.